

Range hoods



Kitchen range



Multi-head furnaces



Ovens



Refrigerators



Dishwashers



Red wine shelf



Microwave

Kimengsi®



KITCHEN APPLIANCES

In addition to design
we also pursue results

Contents

HOOD	1-30
STOVE	31-62
OVEN	63-76
MICROWAVE OVEN	77-78
CONNECTED OVEN	79-82
DISHWASHERS	83-86
RED WINE CABINET	87-94
DISINFECTION CABINET & INTEGRATED GAS COOKER	95-96
REFRIGERATORS	97-102
WASHING MACHINE	103-104
COFFEE MACHINE & WARMING DISC MACHINE	105-108

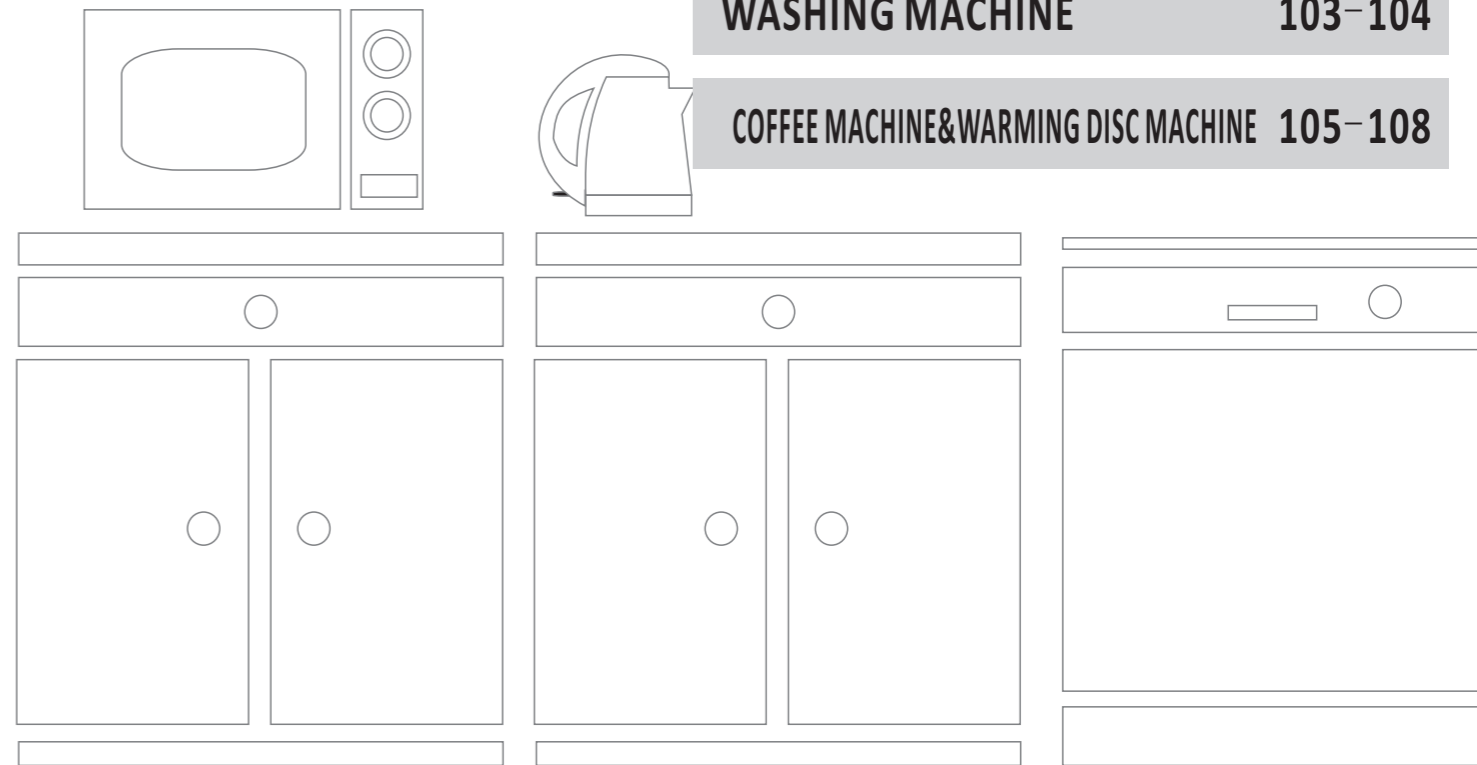
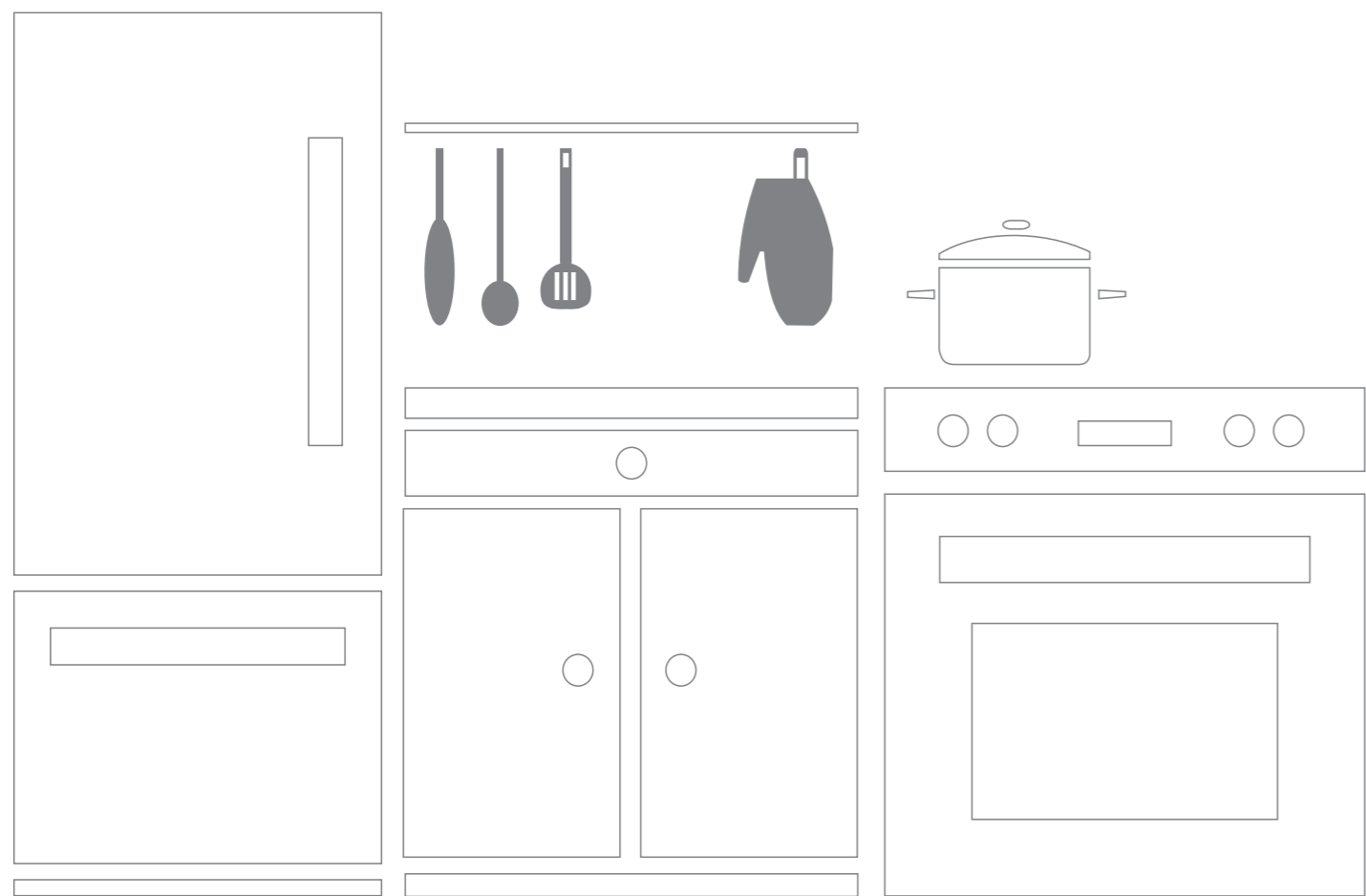

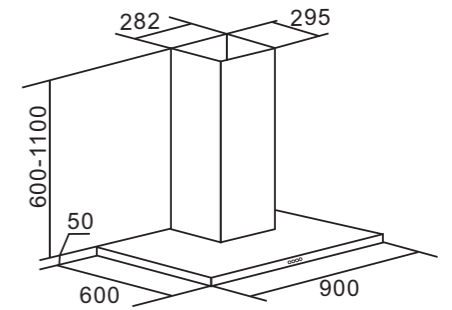

XMS-F13

Material

Stainless steel

Measurement

900MM

Features

💡 LED 4x2W

🔊 3 Speeds

👉 Touch Switch

🌀 28# Single Motor

🌀 Exhaust air rate: 20 (+1.-1) m³/min

Packing

Gross Weight: 30kg (900mm)

Net Weight: 28.5kg (900mm)

Packing Dimensions (HxWxD)

1003x580x680mm



XMS-FC16

Material

White Stainless steel

Measurement

Φ350MM

Features

- 💡 LED 2x2W
- 🔊 3 Speeds
- 🔌 Mechanical Switch
- 🔧 28# Single Motor
- 🌀 Exhaust air rate: 21 (+1.-1) m³/min

Packing

Gross Weight: 18kg

Net Weight: 16kg

Packing Dimensions (HxWxD)

910x390x400mm

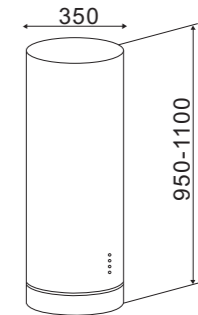

XMS-FC17

Material

Black Stainless steel

Measurement

Φ350MM

Features

- 💡 LED 2x2W
- 🔊 3 Speeds
- 🔌 Mechanical Switch
- 🔧 28# Single Motor
- 🌀 Exhaust air rate: 21 (+1.-1) m³/min

Packing

Gross Weight: 18kg

Net Weight: 16kg

Packing Dimensions (HxWxD)

910x390x400mm

Hidden hood

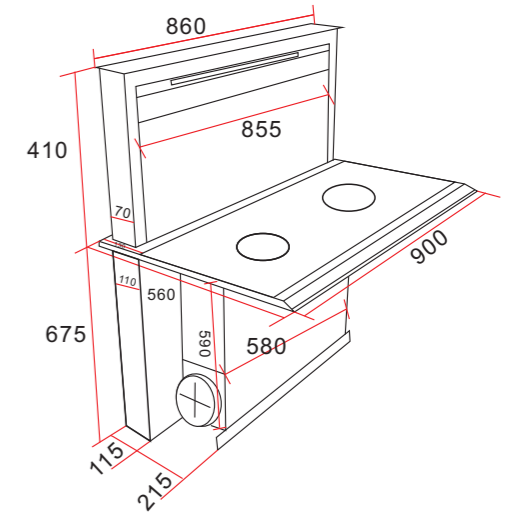

nit: mm
The size of the specific cooker opening is subject to the actual size.

XMS-FHE

Material

S.S & Tempered Glass

Measurement

900MM

Features

- 💡 LED 2x20W
- 📊 3 Speeds LCD Touch Control
- 🔊 Automatically Raises
- 🏠 1x5 layers Washable Aluminum Grease Filters

Optional

- 🔌 Recirculation (Charcoal Filter)
- 📶 Remote Control
- 💡 LED Lighting Panel
- 🌀 Air Flow Range 500/700m³/h

Packing

Gross Weight : 55kg

Net Weight: 53kg

Packing Dimensions (HxWxD)

960x430x780mm



INVISIBLE RANGE HOOD-FC22

Material

Sprayed & Tempered Glass

Measurement

900MM

Features

LED 8W

3 Speeds LCD Touch Control

Automatically Raises

1x5 layers Washable Aluminum Grease Filters

Optional

Recirculation (Charcoal Filter)

Remote Control

LED Lighting Panel

Air Flow Range 500/700m³/h

Packing

Gross Weight :52kg

Net Weight: 50kg

Packing Dimensions(HxWxD)

1040x740x575mm(900mm)

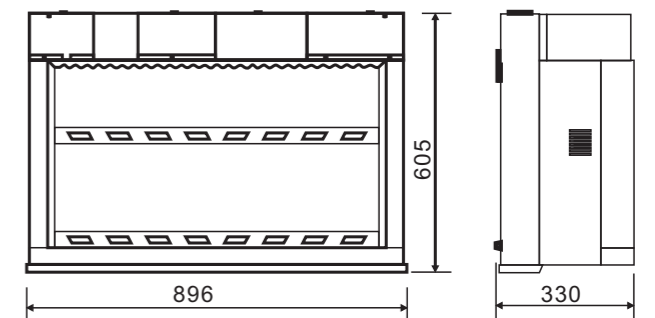



Minimalist white



Desktop Range Hood-FC23

Material

Stainless steel & Tempered Glass

Measurement

900MM

Features

LED 2x2W

3 Speeds LCD Touch Control

2x Baffle Fitter

Optional

Automatic flip + intelligent body feel

Recirculation (Charcoal Filter)

Halogen Light

Air Flow Range 500/1000m³/h

Packing

Gross Weight:49kg

Net Weight:47kg

Packing Dimensions(HxWxD)

950x1170x580mm

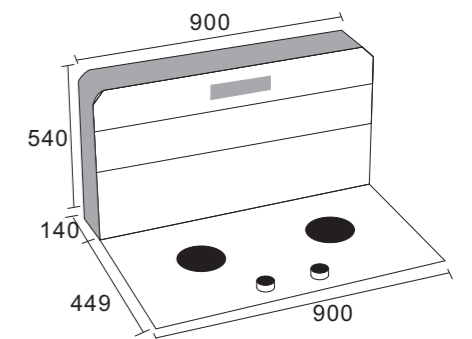

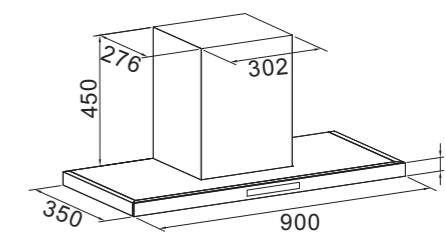

XMS-FC25

Material

Stainless steel + Sprayed

Measurement

900MM

Features

- 💡 LED 2x1.5W
- 🔊 3 Speeds
- 👆 Touch Switch
- 🌀 28# Single Motor
- 🌀 Exhaust air yate: 20(+1.-1) m³/min

Packing

Gross Weight:18kg

Net Weight: 16kg

Packing Dimensions (HxWxD)

940x365x435mm



White



Champagne



Black

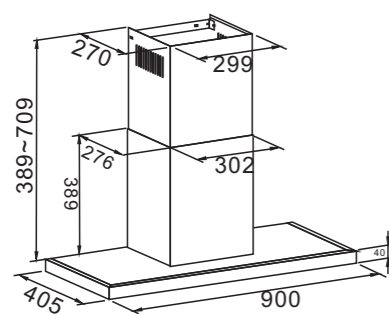

XMS-FC21

Material
Sprayed + Glass
Measurement
900MM
Features

- 💡 LED 2x1.5W
- 🔊 3 Speeds
- 👉 Touch Switch+Somatosensory switch
- 🏠 Single Motor
- 🌀 Exhaust air rate: 20 (+1.-1) m³/min

 Packing
 Gross Weight: 17kg
 Net Weight: 15kg
 Packing Dimensions (HxWxD)
 940x365x435mm

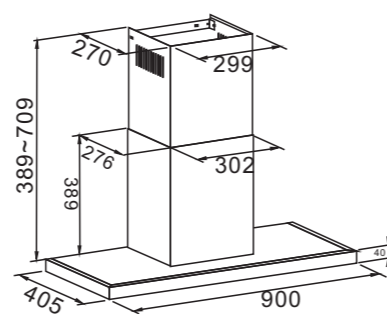

XMS-FC15

Material
S.S&Tempered Glass
Measurement
900MM
Features

- 💡 LED 2x1.5W
- 🔊 3 Speeds
- 👉 Touch Switch+Somatosensory switch
- 🏠 Single Motor
- 🌀 Exhaust air rate: 20 (+1.-1) m³/min

 Packing
 Gross Weight: 18kg
 Net Weight: 16kg
 Packing Dimensions (HxWxD)
 620x400x520mm
 940x365x435mm

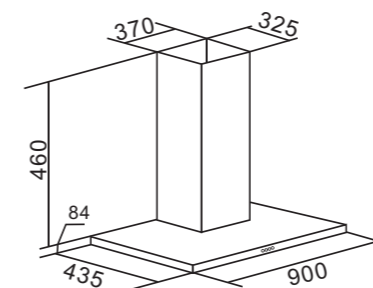

XMS-F03

Material
Stainless steel
Measurement
900MM
Features

- 💡 LED 2x1.5W
- 🔊 3 Speeds
- 👉 Touch Switch+Somatosensory switch
- 🏠 Single Motor
- 🌀 Exhaust air rate: 20 (+1.-1) m³/min

 Packing
 Gross Weight: 17kg
 Net Weight: 15kg
 Packing Dimensions (HxWxD)
 940x570x510mm

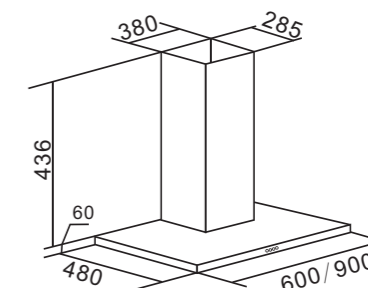

XMS-F10

Material
S.S&Tempered Glass
Measurement
600/900MM
Features

- 💡 LED 2x1.5W
- 🔊 3 Speeds
- 👉 Mechanical Switch
- 🏠 28# Single Motor
- 🌀 Exhaust air rate: 18 (+1.-1) m³/min

 Packing
 Gross Weight: 11/13kg
 Net Weight: 9/11kg
 Packing Dimensions (HxWxD)
 620x400x520mm
 920x400x520mm

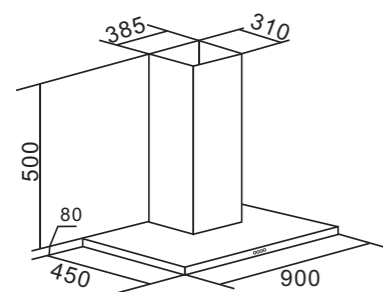

XMS-FC10

Material
Stainless steel & Tempered Glass

Measurement
900MM

Features

- 💡 LED 2x1.5W
- 🔊 3 Speeds
- 👉 Touch Switch+Somatosensory switch
- 🏠 Single Motor
- 🌀 Exhaust air yate: 20(+1.-1) m³/min

Packing

Gross Weight: 19kg

Net Weight : 17kg

Packing Dimensions (HxWxD)

935x620x465mm

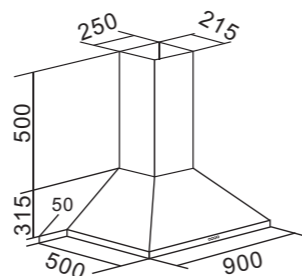

XMS-F09

Material
Stainless steel & Tempered Glass

Measurement
900MM

Features

- 💡 LED 2x1.5W
- 🔊 3 Speeds
- 👉 Mechanical Switch
- 🏠 Single Motor
- 🌀 Exhaust air yate: 18(+1.-1) m³/min

Packing

Gross Weight: 18.5kg

Net Weight: 16.5kg

Packing Dimensions (HxWxD)

650x440x550mm

950x440x550mm

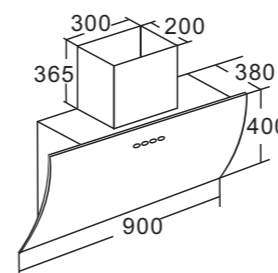

XMS-F15

Material
Stainless steel& Tempered Glass

Measurement
900MM

Features

- 💡 LED 2x1.5W
- 🔊 3 Speeds
- 👉 Touch Switch+Somatosensory switch
- 🏠 Single Motor
- 🌀 Exhaust air yate: 20(+1.-1) m³/min

Packing

Gross Weight: 19kg

Net Weight: 17kg

Packing Dimensions (HxWxD)

950x600x440mm

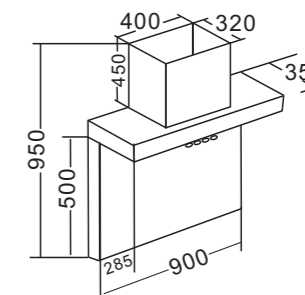

XMS-FC09

Material
Sprayed + Glass

Measurement
900MM

Features

- 💡 LED 2x1.5W
- 🔊 3 Speeds
- 👉 Touch Switch+Somatosensory switch
- 🏠 Single Motor
- 🌀 Exhaust air yate: 20(+1.-1) m³/min

Packing

Gross weight: 25.5kg

Net weight: 23.5kg

Packaging Dimensions(H x W x D)

1060x960x420mm

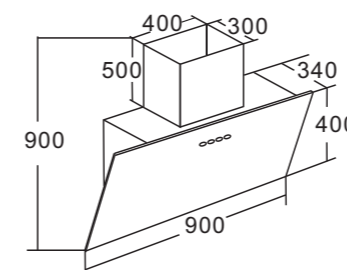

XMS-FC11

Material
Sprayed + Glass
Measurement
900MM
Features

- 💡 LED 2x2W
- 🔊 3 Speeds
- 👆 Touch Switch+Somatosensory switch
- 🔌 Single Motor
- 🌀 Exhaust air rate: 20 (+1.-1) m³/min

Packing
Gross weight: 31kg
Net weight: 29kg
Packaging Dimensions(H x W x D)
955x450x1005mm

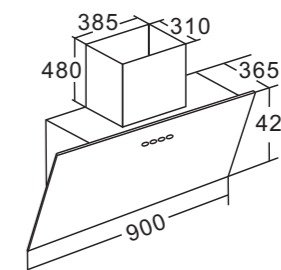

XMS-FC12

Material
Sprayed + Glass
Measurement
900MM
Features

- 💡 LED 2x2W
- 🔊 3 Speeds
- 👆 Touch Switch+Somatosensory switch
- 🔌 Single Motor
- 🌀 Exhaust air rate: 20 (+1.-1) m³/min

Packing
Gross Weight: 21kg
Net Weight: 20kg
Packing Dimensions (HxWxD)
970x510x610mm

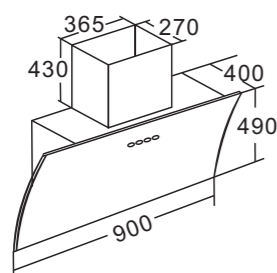

XMS-FC08

Material
Stainless steel & Tempered Glass

Measurement
900MM

Features

- 💡 LED 2x2W
- 🔊 3 Speeds
- 👉 Touch Switch+Somatosensory switch
- 🔧 Double-Motor
- 🌀 Exhaust air rate: 20 (+1.-1) m³/min

Packing

Gross weight: 27kg
Net weight: 25kg
Packaging Dimensions(H x W x D)
960x510x580mm

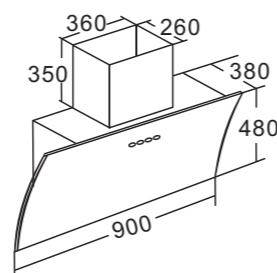

XMS-FC18

Material
Stainless steel & Tempered Glass

Measurement
900MM

Features

- 💡 LED 2x1.5W
- 🔊 3 Speeds
- 👉 Touch Switch+Somatosensory switch
- 🔧 Double-Motor
- 🌀 Exhaust air rate: 20 (+1.-1) m³/min

Packing

Gross Weight: 17kg
Net Weight: 16kg
Packing Dimensions (HxWxD)
940x455x565mm

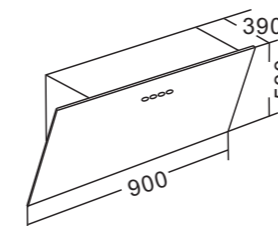

XMS-F16

Material
Sprayed + Glass

Measurement
900MM

Features

- 💡 LED 2x1.5W
- 🔊 3 Speeds
- 👉 Touch Switch
- 🔧 Single Motor
- 🌀 Exhaust air rate: 20 (+1.-1) m³/min

Packing

Gross Weight: 16.5kg
Net Weight: 15kg
Packing Dimensions (HxWxD)
950x470x600mm

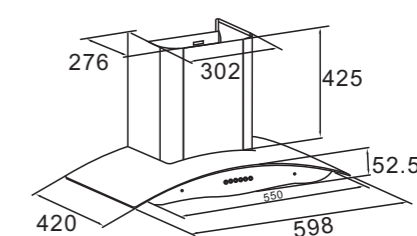

XMS-FC13

Material
Stainless steel & Tempered Glass

Measurement
900MM

Features

- 💡 LED 2x1.5W
- 🔊 3 Speeds
- 👉 Mechanical Switch
- 🔧 Single Motor
- 🌀 Exhaust air rate: 18 (+1.-1) m³/min

Packing

90cm
Gross Weight: 13.5kg
Net Weight: 12.5kg
Packing Dimensions (HxWxD)
930x600x460mm

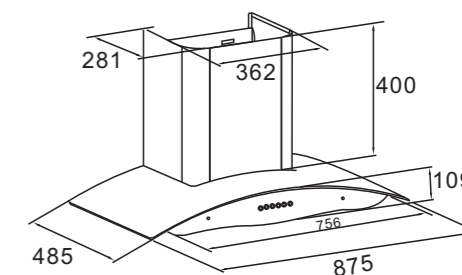

XMS-FC03

Material

White

Measurement

900MM

Features

💡 LED 2x1.5W

📏 3 Speeds

🔌 Touch Switch

🌀 Single Motor

🌀 Exhaust air yate: 18 (+1.-1) m³/min

Packing

Gross Weight: 13.5kg

Net Weight: 12.5kg

Packing Dimensions (HxWxD)

940x570x370mm

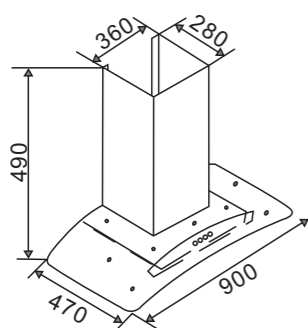

XMS-F01

Material
Stainless steel & Tempered Glass

Measurement
900MM

Features

- 💡 LED 2x1.5W
- 🔊 3 Speeds
- 🔌 Mechanical Switch
- 🏠 Single Motor
- 🌀 Exhaust air rate: 18 (+1.-1) m³/min

Packing

Gross Weight: 16.5kg

Net Weight: 14.5kg

Packing Dimensions(HxWxD)

940x575x555mm

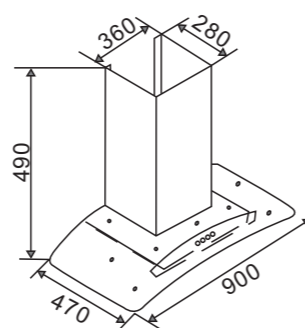

XMS-F02

Material
Stainless steel & Tempered Glass

Measurement
600/900MM

Features

- 💡 LED 2x1.5W
- 🔊 3 Speeds
- 🔌 Mechanical Switch+Color Display Screen
- 🏠 Single Motor
- 🌀 Exhaust air rate: 18 (+1.-1) m³/min

Packing 600mm 900mm

Gross Weight: 13.5 16.5kg

Net Weight: 12.5 14.5kg

Packing Dimensions(HxWxD)

640x575x555mm

940x575x555mm

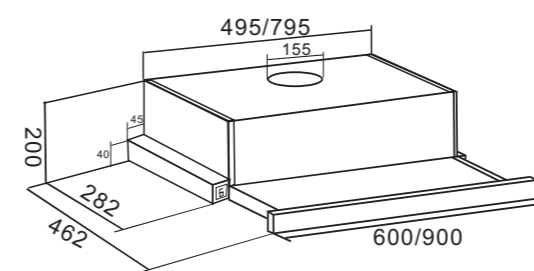

XMS-F04

Material
Stainless steel

Measurement
600/900MM

Features

- 💡 LED 2x1.5W
- 🔊 3 Speeds
- 🔌 Mechanical Switch
- 🏠 Single Motor
- 🌀 Exhaust air rate: 6/12 (+1.-1) m³/min

Packing 600mm 900mm

Gross Weight: 6.2kg 8.6kg

Net Weight: 5.4kg 7.8kg

Packing Dimensions (HxWxD)

937x172x525mm

637x172x525mm

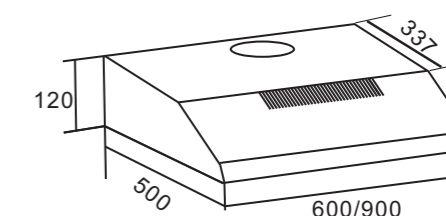

XMS-F06

Material
White

Measurement
600/900MM

Features

- 💡 LED 2x1.5W
- 🔊 3 Speeds
- 🔌 Mechanical switch
- 🏠 600mm Single motor
- 🏠 900mm Double motor
- 🌀 Exhaust air rate: 6/12 (+1.-1) m³/min

Packing 600mm 900mm

Gross Weight: 7kg 8kg

Net Weight: 6kg 7kg

Packing Dimensions (HxWxD)

935x180x535mm

640x180x535mm

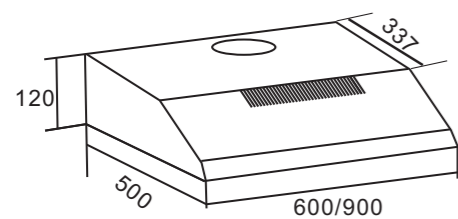

XMS-F07

- Material
Stainless steel
- Measurement
600/900MM
- Features
- 💡 LED 2x1.5W
 - 🔊 3 Speeds
 - 🔌 Mechanical Switch
 - 🌀 600mm Single motor
900mm Double motor
 - 🌀 Exhaust air yate: 6/12 (+1.-1) m³/min

Packing 600mm 900mm
Gross Weight: 7kg 8kg
Net Weight: 6kg 7kg
Packing Dimensions (HxWxD)
935x180x535mm
640x180x535mm

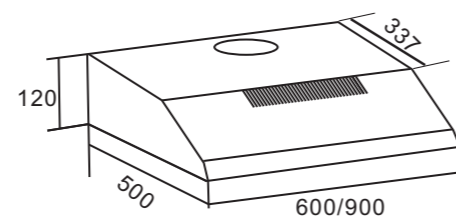

XMS-FC01

- Material
White
- Measurement
600/900MM
- Features
- 💡 LED 2x1.5W
 - 🔊 3 Speeds
 - 🔌 Touch Switch
 - 🌀 600mm Single motor
900mm Double motor
 - 🌀 Exhaust air yate: 6/12 (+1.-1) m³/min

Packing 600mm 900mm
Gross Weight: 7kg 8kg
Net Weight: 6kg 7kg
Packing Dimensions (HxWxD)
935x180x535mm
640x180x535mm

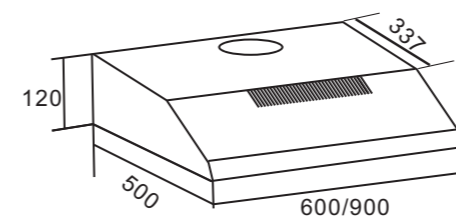

XMS-F08

- Material
Black
- Measurement
600/900MM
- Features
- 💡 LED 2x1.5W
 - 🔊 3 Speeds
 - 🔌 Touch Switch
 - 🌀 600mm Single motor
900mm Double motor
 - 🌀 Exhaust air yate: 6/12 (+1.-1) m³/min

Packing 600mm 900mm
Gross Weight: 7kg 8kg
Net Weight: 6kg 7kg
Packing Dimensions (HxWxD)
935x180x535mm
640x180x535mm

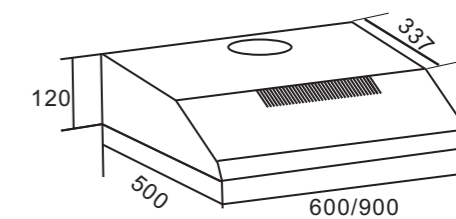

XMS-FC02

- Material
Black
- Measurement
600/900MM
- Features
- 💡 LED 2x1.5W
 - 🔊 3 Speeds
 - 🔌 Touch Switch
 - 🌀 600mm Single motor
900mm Double motor
 - 🌀 Exhaust air yate: 6/12 (+1.-1) m³/min

Packing 600mm 900mm
Gross Weight: 7kg 8kg
Net Weight: 6kg 7kg
Packing Dimensions (HxWxD)
935x180x535mm
640x180x535mm

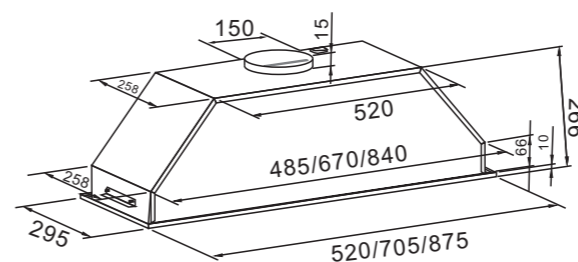

XMS-FC19

- Material
Stainless steel
- Measurement
900MM
- Features
 - 💡 LED 2x1.5W
 - 📶 3 Speeds
 - 👉 Touch Switch+Somatosensory switch
 - 🔊 28# Single Motor
 - 🌀 Exhaust air yate: 20 (+1.-1) m³/min

Packing	520mm	702mm	875mm
Gross Weight:	7kg	8kg	9kg
Net Weight:	6kg	7kg	8kg
Packing Dimensions (HxWxD)	935x180x535mm		
	640x180x535mm		

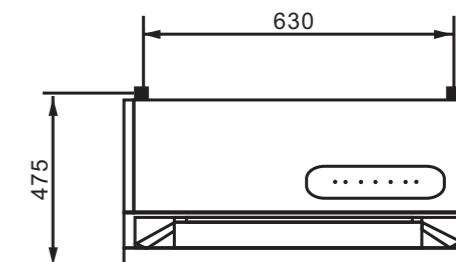

XMS-FC20

- Material
Stainless steel & Tempered Glass
- Measurement
700MM
- Features
 - 💡 LED 2x2W
 - 📶 3 Speeds
 - 👉 Touch Switch
 - 🔊 Single Motor
 - 🌀 Exhaust air yate: 20 (+1.-1) m³/min

Packing	600mm	900mm
Gross Weight:	7kg	8kg
Net Weight:	6kg	7kg
Packing Dimensions (HxWxD)	935x180x535mm	
	640x180x535mm	

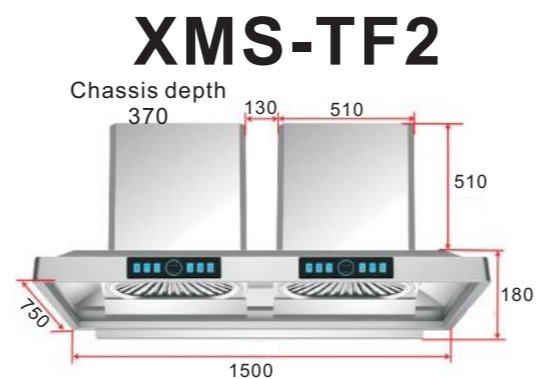

Speed Wind Series-Double Head

YX-1.5m Double Head

TECHNICAL PARAMETERS

Configuration/Configuation

1600W Full Seal Copper, Oil Free Teflon Gold Wind Wheel

Switch Type: All Aluminum Alloy Integral Molding Touch Switch

Material: Stainless steel Air Volume: 36m/min

Pipe diameter: medium 200mm Meximum static pressure:670pa

Body size: 1500 x 750 x 690 mm

Face Mask Carton Size: 1575 x 210 x 855 mm

Bellows Carton Size: 575 x 435 x 630 mm



XMS-TF1



Speed Wind Series - Single Head

YX-1.2m Single Head

TECHNICAL PARAMETERS

Configuration/Configuation

800W all-sealed copper, non-stick Teflon gold wind wheel

Switch type: all aluminum alloy integral body + touch switch

Material: Stainless steel

Air volume:36m/min

Pipe diameter: medium 200mm

Meximum static pressure:670pa

Body size: 1200 x 750 x 690 MM

FaceMask Carton Size: 1285 x 210 x 855MM

Bellows Carton Size: 575 x435 x630MM



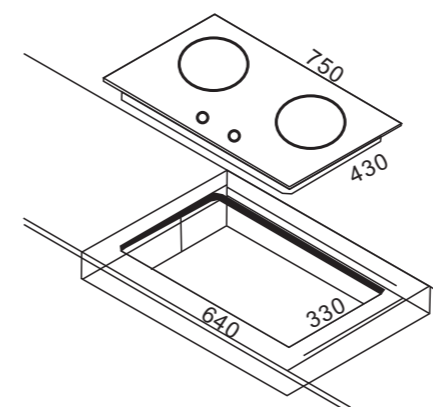

XMS-R16

Features

Panel Material: S.S

2 Gas Burner

Material Of Furnace frame: Cast iron

Burning firepower Value:

LPG:5.2+5.2KW

Optional

Gas Source: LPG/NG

Packing

Gross Weight:13kg

Net Weight: 12kg

Packing Dimensions (HxWxD)

800x480x200mm

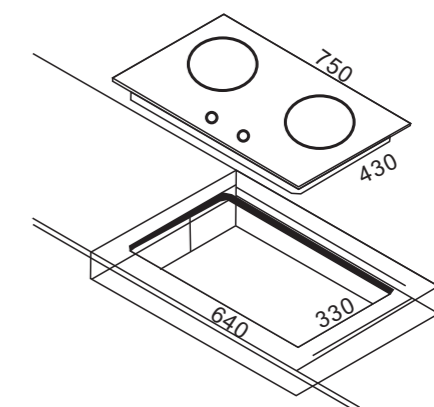

XMS-R15

Features

Panel Material: Toughened Glass

2 Gas Burner

Material Of Furnace frame: Cast iron

Burning firepower Value:

LPG:5.2+5.2KW

Optional

Gas Source: LPG/NG

Packing

Gross Weight:15kg

Net Weight: 14kg

Packing Dimensions (HxWxD)

800x480x200mm

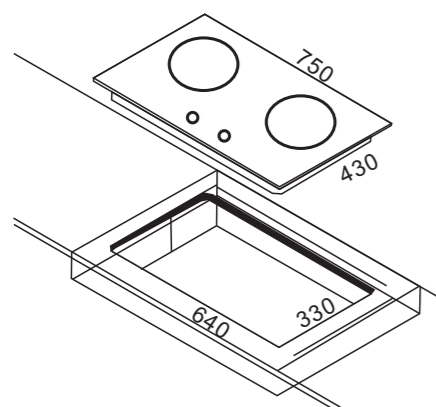

XMS-R02

Features

Panel Material: S. S

2 Gas Burner

Material Of Furnace frame: Cast iron

Burning firepower Value:

LPG:4.8+4.8KW

Optional

Gas Source: LPG/NG

Packing

Gross Weight:10kg

Net Weight: 9kg

Packing Dimensions (HxWxD)

800x480x200mm

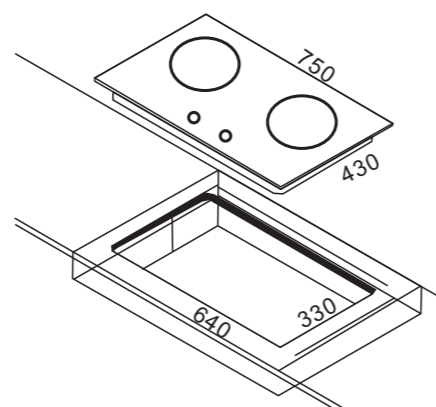

XMS-R07

Features

Panel Material: Toughened Glass

2 Gas Burner

Material Of Furnace frame: Cast iron

Burning firepower Value:

LPG:5.0+5.0KW

Optional

Gas Source: LPG/NG

Packing

Gross Weight:12kg

Net Weight: 11kg

Packing Dimensions (HxWxD)

790x470x230mm

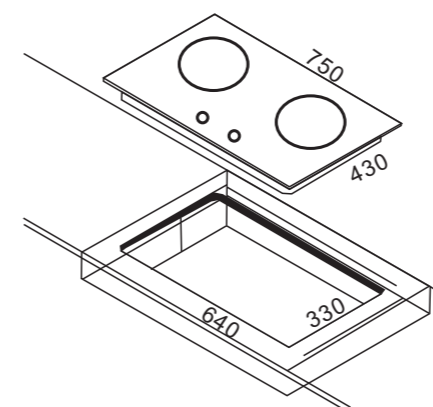

XMS-R10

Features

Panel Material: Toughened Glass

1 Gas Burner + 1 Electric

Material Of Furnace frame: Cast iron

Burning firepower Value:

LPG:2200W+5.2KW

Optional

Gas Source: LPG/NG

Packing

Gross Weight:15kg

Net Weight: 14kg

Packing Dimensions (HxWxD)

800x480x200mm

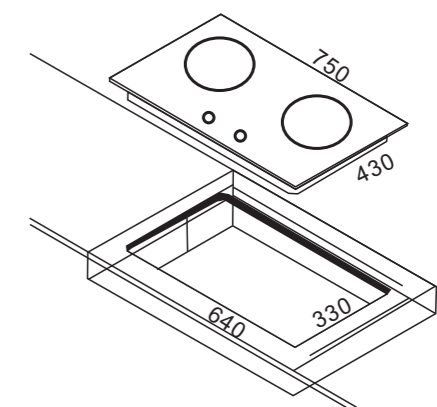

XMS-R11

Features

Panel Material: Toughened Glass

2 Gas Burner

Material Of Furnace frame: Cast iron

Burning firepower Value:

LPG:5.0+5.2KW

Optional

Gas Source: LPG/NG

Packing

Gross Weight:15kg

Net Weight: 14kg

Packing Dimensions (HxWxD)

805x480x205mm

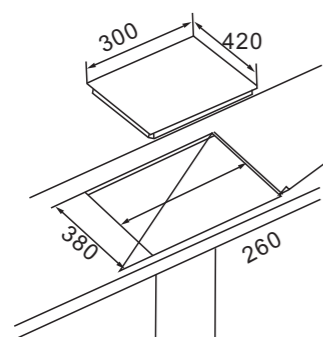

XMS-R01

Features

Panel Material: S.S

1 Gas Burner

Material Of Furnace frame: Cast iron

Burning firepower Value:

LPG:4.0KW

Optional

Gas Source: LPG/NG

Packing

Gross Weight:6kg

Net Weight: 5kg

Packing Dimensions (HxWxD)

470x370x200mm

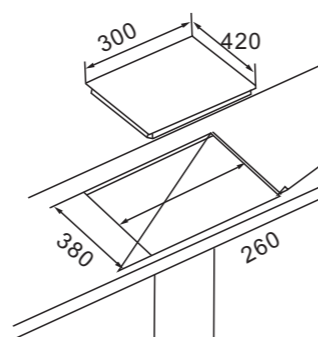

XMS-R06

Features

Panel Material: Toughened Glass

1 Gas Burner

Material Of Furnace frame: Cast iron

Burning firepower Value:

LPG:4.0KW

Optional

Gas Source: LPG/NG

Packing

Gross Weight:6.5kg

Net Weight: 5.5kg

Packing Dimensions (HxWxD)

470x370x200mm

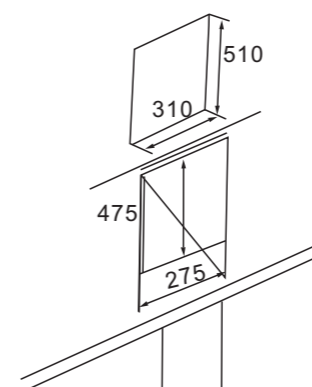

XMS-A01

Features

Panel Material: S.S

2 Gas Burner

Material Of Furnace frame: Cast iron

Burning firepower Value:

LPG:3.3+1.0KW

Optional

Gas Source: LPG/NG

Packing

Gross Weight:7kg

Net Weight: 6kg

Packing Dimensions (HxWxD)

560x360x170mm

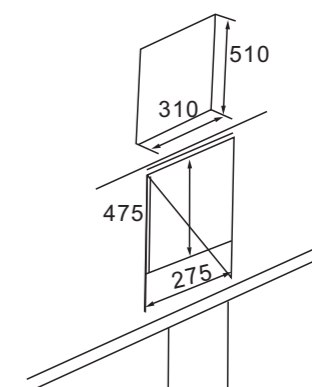

XMS-A02

Features

Panel Material: Toughened Glass

2 Gas Burner

Material Of Furnace frame: Cast iron

Burning firepower Value:

LPG:3.3+1.0KW

Optional

Gas Source: LPG/NG

Packing

Gross Weight:7kg

Net Weight: 6kg

Packing Dimensions (HxWxD)

560x360x170mm

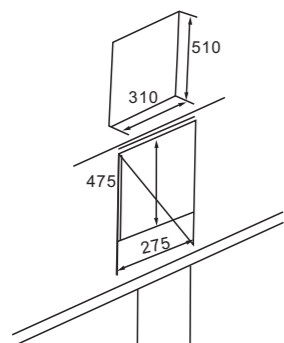

XMS-A03

Features

Panel Material: S.S

2 Electric Furnace

Material Of Furnace frame: Cast iron

Power:

LPG:1500W+450W

Optional

Gas Source: LPG/NG

Packing

Gross Weight:6.5kg

Net Weight: 5.5kg

Packing Dimensions (HxWxD)

560x360x170mm

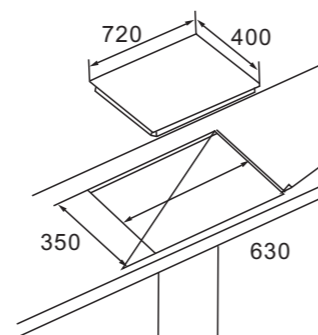

XMS-A09

Features

Panel Material: S.S

3 Gas Burner

Material Of Furnace frame: Cast iron

Burning firepower Value:

LPG:3.3+3.3+1.75KW

Optional

Gas Source: LPG/NG

Packing

Gross Weight:11kg

Net Weight: 10kg

Packing Dimensions (HxWxD)

770x440x200mm

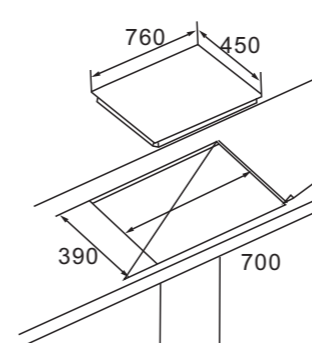

XMS-B2

Features

Panel Material: Toughened Glass

3 Gas Burner

Material Of Furnace frame: Cast iron

Burning firepower Value:

LPG:3.3+3.3+1.0KW

Optional

Gas Source: LPG/NG

Packing

Gross Weight:13.5kg

Net Weight: 12.5kg

Packing Dimensions (HxWxD)

920x550x150mm

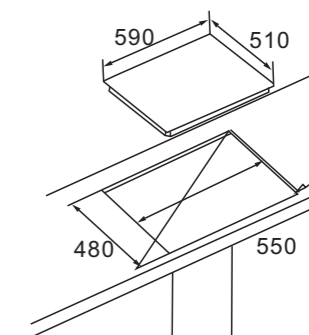

XMS-A08

Features

Panel Material: S.S

4 Gas Burner

Material Of Furnace frame: Cast iron

Burning firepower Value:

LPG:3.3+1.75+1.75+1.0KW

Optional

Gas Source: LPG/NG

Packing

Gross Weight:9.7kg

Net Weight: 9kg

Packing Dimensions (HxWxD)

640x550x140mm

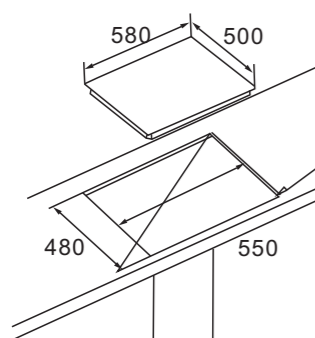

CMS-A05

Features

Panel Material: S.S

2 Gas Burner+ 1 Electric Furnace

Material Of Furnace frame: Cast iron

Burning firepower Value:

LPG:1.75+1.75+1.0KW+1000W

Optional

Gas Source: LPG/NG

Packing

Gross Weight:10kg

Net Weight: 9kg

Packing Dimensions (HxWxD)

640x550x140mm

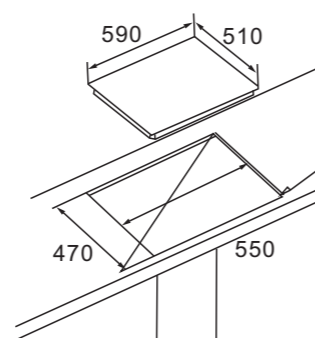

XMS-A07

Features

Panel Material: S.S

4 Electric Furnace

Material Of Furnace frame: Cast iron

Burning firepower Value:

LPG:1500W+1000W+1000W+450W

Optional

Gas Source: LPG/NG

Packing

Gross Weight:9.5kg

Net Weight: 8.5kg

Packing Dimensions (HxWxD)

700x560x170mm

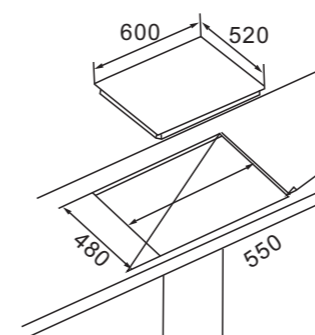

XMS-A32

Features

Panel Material: Toughened Glass

4 Gas Burner

Material Of Furnace frame: Cast iron

Burning firepower Value:

LPG:3.3+1.75+1.75+1.0KW

Optional

Gas Source: LPG/NG

Packing

Gross Weight:13.5kg

Net Weight: 12.5kg

Packing Dimensions (HxWxD)

680x580x160mm

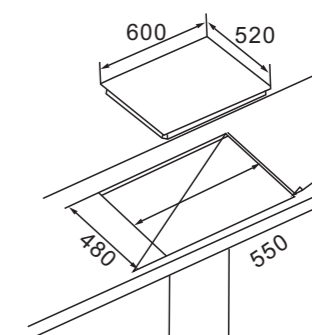

XMS-A16

Features

Panel Material: Toughened Glass

4 Gas Burner

Material Of Furnace frame: Cast iron

Burning firepower Value:

LPG:3.3+1.75+1.75+1.0KW

Optional

Gas Source: LPG/NG

Packing

Gross Weight:11.5kg

Net Weight: 10.5kg

Packing Dimensions (HxWxD)

650 x 560 x 140mm



XMS-A36

Features

Panel Material: S.S

2 Gas Burner

Material Of Furnace frame: Cast iron

Burning firepower Value:

LPG:5.0KW x 2 + 1.3KW x 2

NG:5.2KW x 2 + 1.8KW x 2

Optional

Gas Source: LPG/NG

Packing

Gross Weight:25kg

Net Weight: 21kg

Packing Dimensions (HxWxD)

975x600x245mm

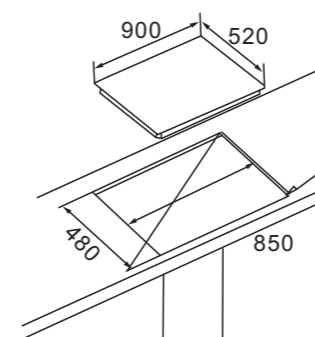
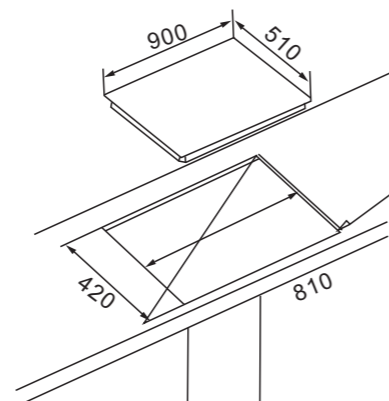

XMS-A18B

Features

Panel Material: Toughened Glass

2 Gas Burner

Material Of Furnace frame: Cast iron

Burning firepower Value:

LPG:3.3+3.0+1.75+1.75+1.0KW

Optional

Gas Source: LPG/NG

Packing

Gross Weight:18.5kg

Net Weight: 17.5kg

Packing Dimensions (HxWxD)

920x546x150mm

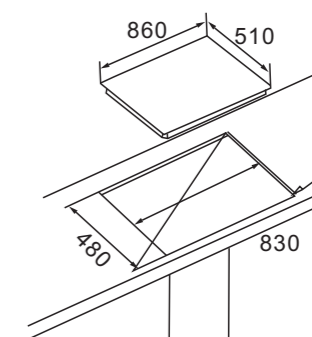

XMS-870B2

Features

Panel Material: S.S

4 Gas Burner +1 Radiant-cooker

Material Of Furnace frame: Cast iron

Burning firepower Value:

LPG:2.75+1.75+1.75+1.0KW+1800W

Optional

Gas Source: LPG/NG

Packing

Gross Weight:15kg

Net Weight: 14kg

Packing Dimensions (HxWxD)

900x550x180mm

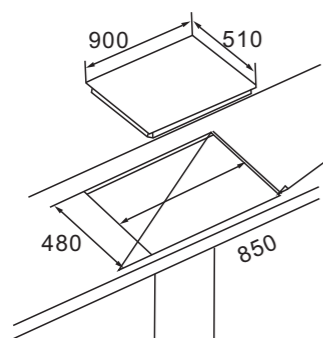

XMS-B3

Features

Panel Material: Toughened Glass

5 Gas Burner

Material Of Furnace frame: Cast iron

Burning firepower Value:

LPG:3.3+3.0+1.75+1.75+1.0KW

Optional

Gas Source: LPG/NG

Packing

Gross Weight:18.5kg

Net Weight: 17.5kg

Packing Dimensions (HxWxD)

920x546x150mm

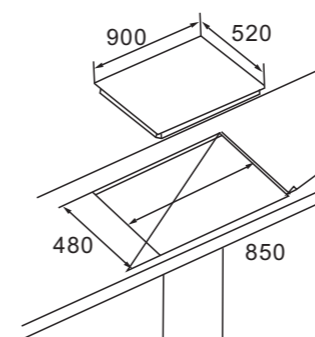

XMS-A31

Features

Panel Material: Toughened Glass

+Micrystal

4 Gas Burner+1 Induction

Material Of Furnace frame: Cast iron

Burning firepower Value:

LPG:2.75+1.75+1.75+1.0KW+1200W

Optional

Gas Source: LPG/NG

Packing

Gross Weight:17.5kg

Net Weight: 16.5kg

Packing Dimensions (HxWxD)

920 x 546 x 150mm

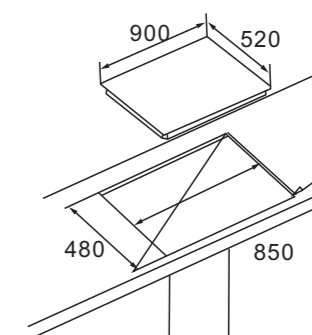

XMS-A18(AB)

Features

Panel Material: Toughened Glass

5 Gas Burner

Material Of Furnace frame: Cast iron

Burning firepower Value:

LPG:3.3+3.0+1.75+1.75+1.0KW

Optional

Gas Source: LPG/NG

Packing

Gross Weight:17.5kg

Net Weight: 16.5kg

Packing Dimensions (HxWxD)

920 x 546 x 150mm

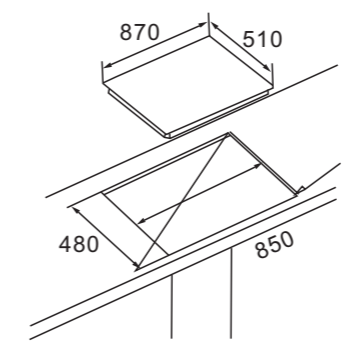

XMS-870B1

Features
 Panel Material: S.S
 5 Gas Burner
 Material Of Furnace frame: Cast iron
 Burning firepower Value:
 LPG:3.3+3.0+1.75+1.75+1.0KW
 Optional
 Gas Source: LPG/NG
 Packing
 Gross Weight:14.5kg
 Net Weight: 13.5kg
 Packing Dimensions (HxWxD)
 920x550x130mm

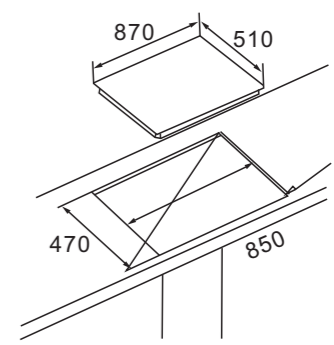

XMS-A14

Features
 Panel Material: S.S
 6 Gas Burner
 Material Of Furnace frame: Cast iron
 Burning firepower Value:
 LPG:3.3+3.0+1.75+1.75+1.75+1.0KW
 Optional
 Gas Source: LPG/NG
 Packing
 Gross Weight:15kg
 Net Weight: 14kg
 Packing Dimensions (HxWxD)
 915x560x140mm



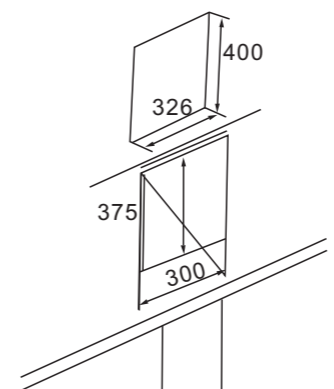
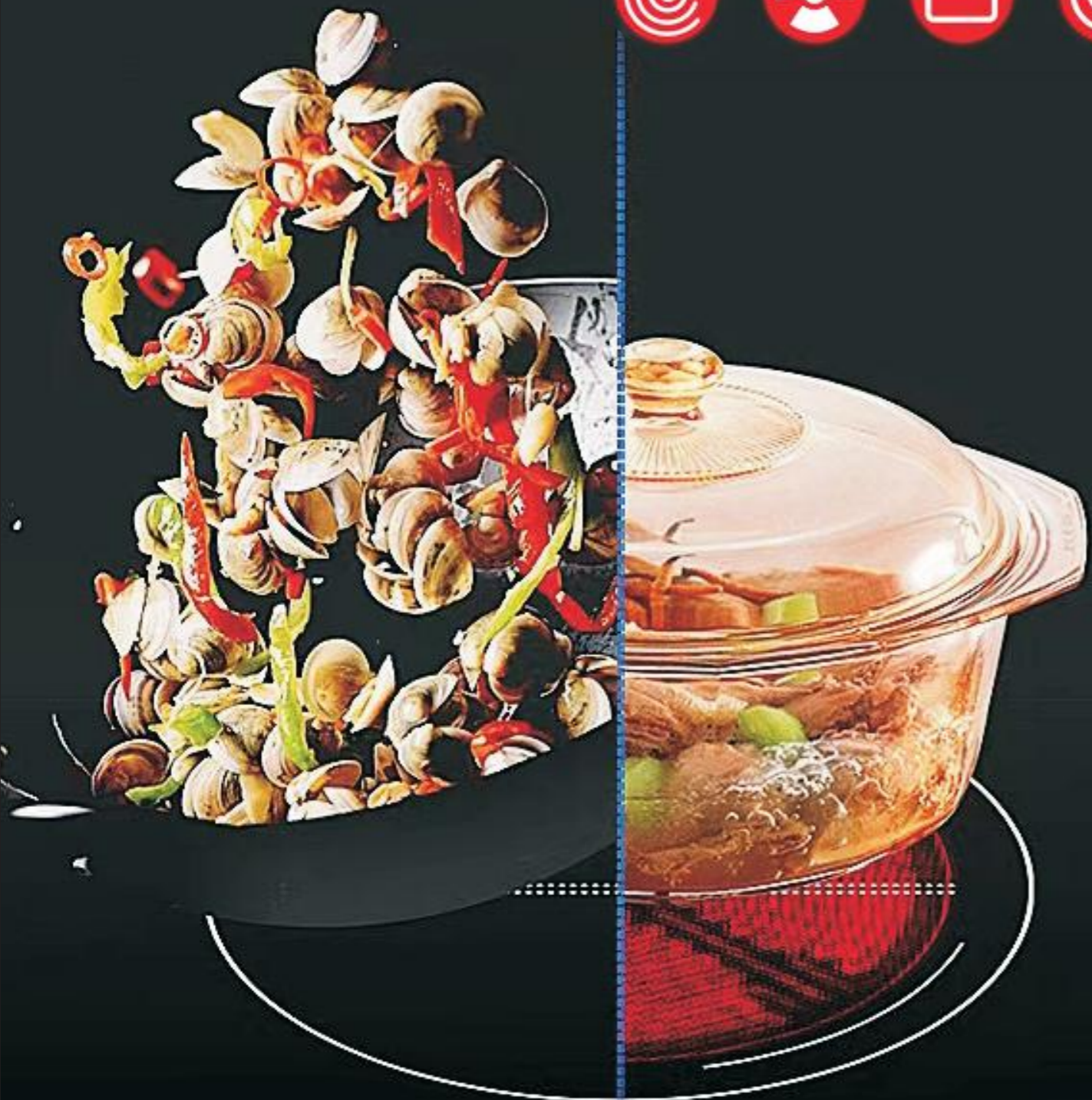

CMS-A20

Features
 Panel Material: Microcrystal
 1 Induction cooker
 Touch Screen
 Overheat Protection
 Power: 2200W

Packing
 Gross Weight: 5kg
 Net Weight: 4kg
 Packing Dimensions (HxWxD)
 490 x 370 x 170mm

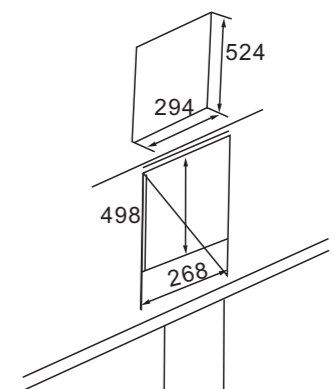

CMS-A21

Features
 Panel Material: Microcrystal
 2 Induction cooker
 Touch Screen
 Overheat Protection
 Power: 2200W+2000W

Packing
 Gross Weight: 9kg
 Net Weight: 8kg
 Packing Dimensions (HxWxD)
 570 x 140 x 355mm

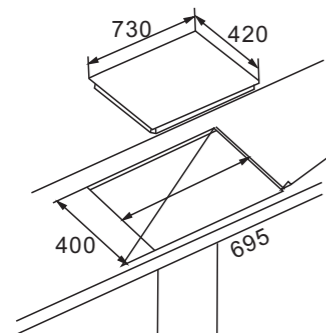
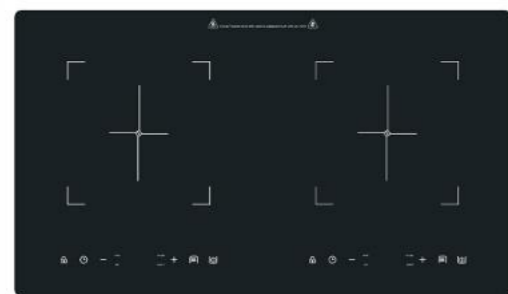

XMS-FD2

- Features**
- Panel Material: Microcrystal**
- 2 Radiant-cooker**
- Touch Screen**
- Automatic Constant Temperature**
- Power: 2200W x 2**
- Packing**
- Gross Weight: 10kg**
- Net Weight: 9kg**
- Packing Dimensions (HxWxD)**
- 800 x 490 x 190mm**

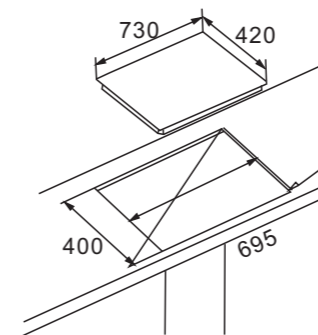

XMS-A25

- Features**
- Panel Material:**
- Microcrystal+Toughened Glass**
- 2 Induction Cooker**
- Touch Screen**
- Overheat Protection**
- Power: 2000W + 2000W**

- Packing**
- Gross Weight: 10kg**
- Net Weight: 9kg**
- Packing Dimensions (HxWxD)**
- 470 x 800 x 150mm**

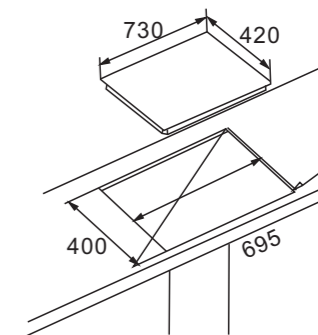

XMS-A26

- Features**
- Panel Material:**
- Microcrystal+Toughened Glass**
- 2 Radiant-cooker**
- Touch Screen**
- Automatic Constant Temperature**
- Power: 2000W + 2000W**

- Packing**
- Gross Weight: 10kg**
- Net Weight: 9kg**
- Packing Dimensions (HxWxD)**
- 470 x 800 x 150mm**

4D Waterproof Black Crystal Panel

Prevent short circuit of soup and water from entering the machine

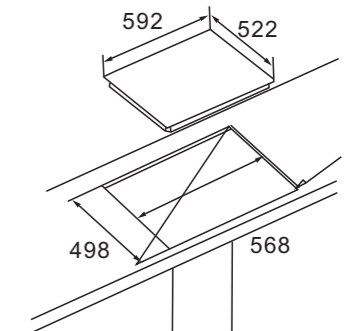

XMS-A23

Features

Panel Material: Microcrystal

4 Induction cooker

Touch Screen

Overheat Protection

Power: 2000W x 4

Packing

Gross Weight: 12kg

Net Weight: 11kg

Packing Dimensions (HxWxD)

640 x 580 x 170mm

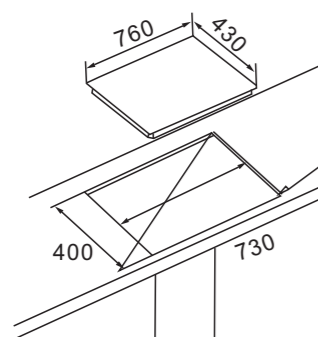

XMS-FD3

Features

Panel Material: Microcrystal
4 Radiant-cooker
Touch Screen
Automatic Constant Temperatu
Power: 2000W+1200W+2200W

Packing

Gross Weight: 12.5kg
Net Weight: 11.5kg
Packing Dimensions (HxWxD)
800 x 470 x 140mm

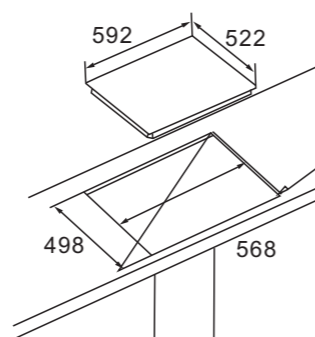

XMS-A24

Features

Panel Material: Microcrystal
4 Induction cooker
Touch Screen
Automatic Constant Temperatu
Power: 2000W x 4

Packing

Gross Weight: 12kg
Net Weight: 11kg
Packing Dimensions (HxWxD)
640 x 580 x 170mm

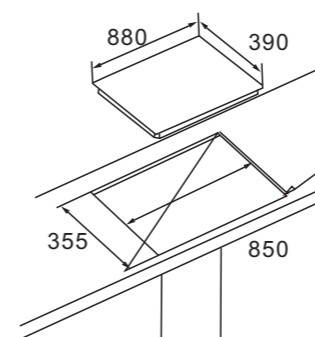
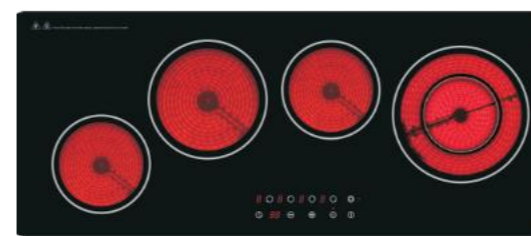

XMS-D03



Features

Panel Material:
Imported the latest diamond technology
black crystal plate, high temperature
resistance, easy to clean
Automatic Constant Temperatu
Power: 2200W+1800W+1200W+1200W

Packing

Gross Weight: 12.5kg
Net Weight: 11.5kg
Packing Dimensions (HxWxD)
950 x 450 x 150mm

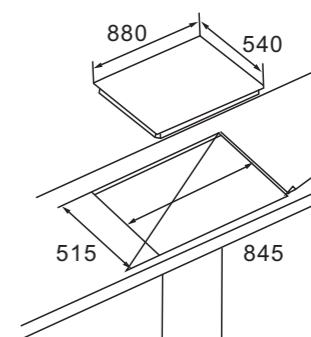

XMS-A28

Features

Panel Material: Microcrystal
5 Induction cooker
Touch Screen
Overheat Proction
Power: 2000W x 5

Packing

Gross Weight: 16.5kg
Net Weight: 15.5kg
Packing Dimensions (HxWxD)
950 x 610 x 165mm

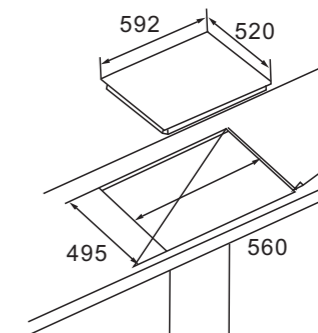

XMS-A22

Features

Panel Material: Microcrystal

2 Gas +2 Werheat

Touch Screen

Overheat Protection

Power: 3.3KW+2.3KW+1800W+1300W

Packing

Gross Weight:14kg

Net Weight: 11kg

Packing Dimensions (HxWxD)

580 x 670 x 200mm



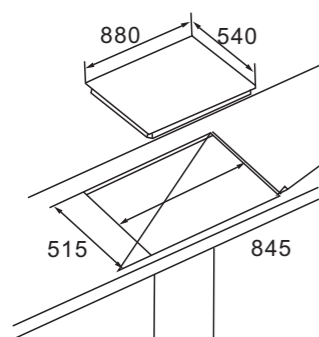

XMS-A29

Features

Panel Material: Microcrystal
5 Radiant-cooker
Touch Screen
Automatic Constant Temperatu
Power: 2000W x 5

Packing

Gross Weight: 17.5kg
Net Weight: 16.5kg
Packing Dimensions (HxWxD)
970 x 610 x 170mm

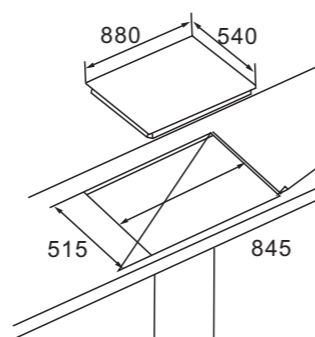

XMS-A27

Features

Panel Material: Microcrystal
6 Induction cooker
Touch Screen
Overheat Proction
Power: 2000W x 6

Packing

Gross Weight: 18kg
Net Weight: 17kg
Packing Dimensions (HxWxD)
950 x 620 x 180mm

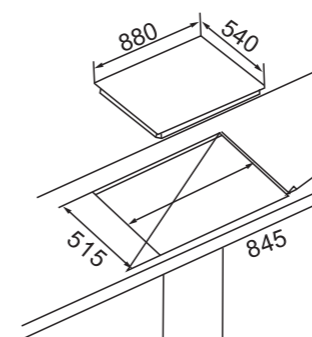

XMS-A30

Features

Panel Material: Microcrystal
6 Radiant-cooker
Touch Screen
Automatic Constant Temperatu
Power: 2000W x 6

Packing

Gross Weight: 18kg
Net Weight: 17kg
Packing Dimensions (HxWxD)
950 x 620 x 180mm





High Power
Commercial kitchen series



XMS-SY01

Flat Dial Key Model 3000 W

Metal stainless steel wire drawing shell Titanium pane
Touch the key control design, the overall beautiful and durable
Exclusively for commercial use, hotels, restaurants,
large -scale cooking use, using the latest diamond microcrystalline technology
The latest integrated chip technology, more stable performance,
greater power and more reliable

Power: 4X3000W Voltage:220V~50Hz Size: 1338x420x170mm



XMS-SY02

Flat Dial Key Model 3000 W

Metal stainless steel wire drawing shell Titanium pane
Touch the key control design, the overall beautiful and durable
Exclusively for commercial use, hotels, restaurants,
large -scale cooking use, using the latest diamond microcrystalline technology
The latest integrated chip technology, more stable performance,
more reliable power

Power: 6X3000W Voltage:220V~50Hz Size: 990x730x790mm



XMS-SY03

Table type low back frying furnace

Frontal voltage (V~50Hz)	Frontal power (KW)	External dimensions (CM)	Pan diameter (CM)	Fire switch	monitor	Microcrystalli plate (CM)
380	12	80×90×80+40	Φ60	8 speed magnetron switch	Large color screen	Iron pot
380	15	90×100×80+40	Φ70	8 speed magnetron switch	Large color screen	Iron pot
380	20	100×110×80+40	Φ80	8 speed magnetron switch	Large color screen	Iron pot
380	25	110×120×80+40	Φ90	8 speed magnetron switch	Large color screen	Iron pot
380	30	120×130×80+40	Φ100	8 speed magnetron switch	Large color screen	Iron pot



380V / 8KW / 10KW



XMS-SY05

Double Head and Single Tail Frying Stove

Frontal voltage (V~50Hz)	Frontal power (KW)	External dimensions (CM)	Pan diameter (CM)	Fire switch	monitor	Microcrystalli plate (CM)
380	8+12	180×100×80+40	Φ50+50	8 speed magnetron switch	Large color screen	Φ40
380	10+15	180×100×80+40	Φ50+50	8 speed magnetron switch	Large color screen	Φ40



High Power
Commercial kitchen series

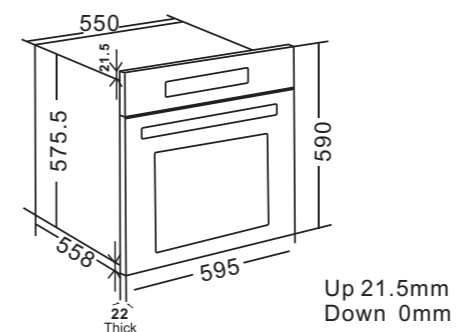

XMS-T105 A10

Features 

Panel material: S.S
Capacity 70L
Function Options: 8
Power: 2300W
Cooling Fan
Control Mode:
Touch Switch
120 minute Mechanical Timing
Led Display Screen
3 Layer Toughened Glass Oven Door
Standard Accessory
Baking Tray: 1Pcs Oven Rack: 1Pcs
Barbecue Fork: 1Pcs
Packing
Gross weight: 35kg
Net weight: 33kg
Package size: (HxWxD)
655X695X655mm

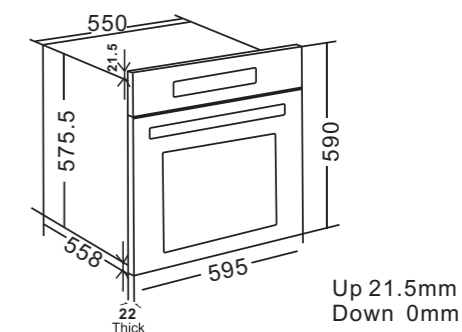

XMS-T100(A10)

Features 

Panel material: Toughened Glass
Capacity 70L
Function Options: 8
Power: 2300W
Cooling Fan
Control Mode:
Touch Switch
120 minute Mechanical Timing
Led Display Screen
3 Layer Toughened Glass Oven Door
Standard Accessory
Baking Tray: 1Pcs Oven Rack: 1Pcs
Barbecue Fork: 1Pcs
Packing
Gross weight: 35kg
Net weight: 33kg
Package size: (HxWxD)
655X695X655mm

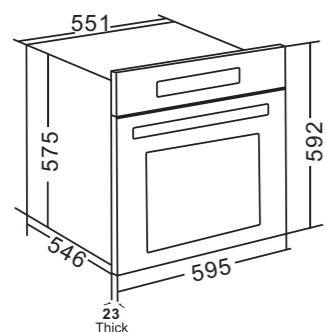

XMS-D06

Features



Panel material: Toughened Glass
60cm Electric Oven
220V/50Hz
Capacity 73L
Function Options: 9
Power: 2700W-3220W
Mechanical Control
With 3 Key Touch Digital Timer
Cooling Fan
Convection Fan
Control Mode:
Mechanical Control System
Packing
Gross weight: 35kg
Net weight: 33kg
Package size: (HxWxD)
650X655X660mm

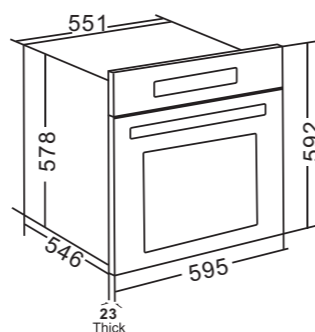

XMS-D08

Features



Panel material: S.S
60cm Electric Oven
220V/50Hz
Capacity 73L
Function Options: 9
Power: 2700W-3220W
Mechanical Control
With 3 Key Touch Digital Timer
Cooling Fan
Convection Fan
Control Mode:
Mechanical Control System
Packing
Gross weight: 35kg
Net weight: 33kg
Package size: (HxWxD)
650X655X660mm

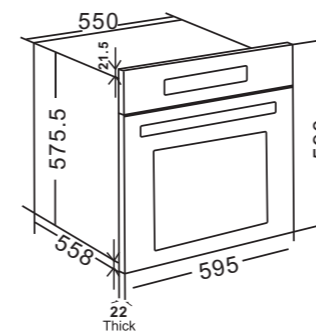

Up 21.5mm
Down 0mm

XMS-T100 B10

Features



Panel material: White Toughened Glass
Capacity 70L
Function Options: 6
Power: 2300W
Cooling Fan
Control Mode:
Mechanical Control System
120 minute Mechanical Timing
3-Layer tempered Glass Door
Standard Accessory
Baking Tray: 1Pcs Oven Rack: 1Pcs
Barbecue Fork: 1Pcs
Packing
Gross weight: 35kg
Net weight: 33kg
Package size: (HxWxD)
655X695X655mm

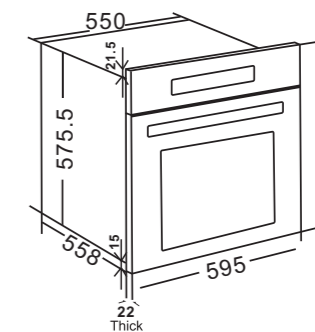

Up 21.5mm
Down 15mm

XMS-63MG Gas

Features



Panel material: Toughened Glass
Capacity 70L
Gas Oven
Power: 2300W
Cooling Fan
Control Mode:
Mechanical Control System
120 minute Mechanical Timing
3-Layer tempered Glass Door
Standard Accessory
Baking Tray: 1Pcs Oven Rack: 1Pcs
Packing
Gross weight: 33kg
Net weight: 30kg
Package size: (HxWxD)
650X655X660mm

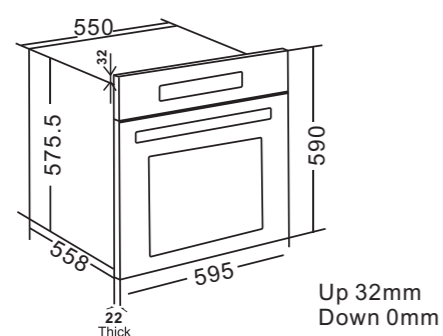

XMS-D01

Features 

Panel material: Toughened Glass
Capacity 61L
Function Options: 5+ECO
Power: 2300W
Cooling Fan
Control Mode:
Mechanical Control System
120 minute Mechanical Timing
Double Layered Glass Oven Door
Standard Accessory
Baking Tray: 1Pcs Oven Rack: 1Pcs
Packing
Gross weight: 33kg
Net weight: 30kg
Package size: (HxWxD)
660X577X650mm

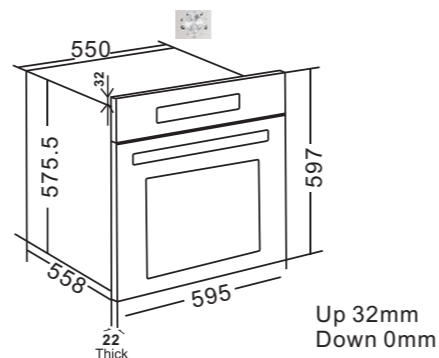

XMS-D02

Features 

Panel material: S.S
Capacity 61L
Function Options: 5+ECO
Power: 2300W
Cooling Fan
Control Mode:
Mechanical Control System
120 minute Mechanical Timing
Double Layered Glass Oven Door
Standard Accessory
Baking Tray: 1Pcs Oven Rack: 1Pcs
Packing
Gross weight: 33kg
Net weight: 30kg
Package size: (HxWxD)
650X655X660mm

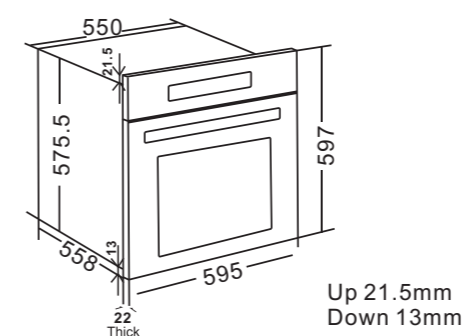

XMS-060

Features 

Panel material: S.S
Capacity 70L
Function Options: 6
Power: 2300W
Cooling Fan
Control Mode:
Mechanical Control System
120 minute Mechanical Timing
3 Layer Toughened Glass Oven Door
Standard Accessory
Baking Tray: 1Pcs Oven Rack: 1Pcs
Barbecue Fork: 1Pcs
Packing
Gross weight: 35kg
Net weight: 33kg
Package size: (HxWxD)
650X655X660mm

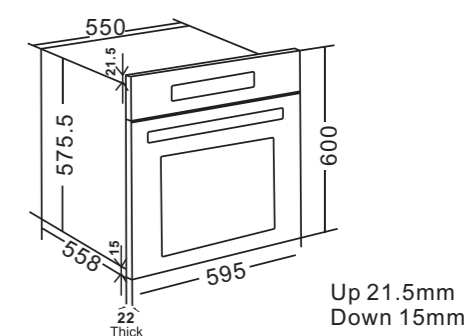

XMS-65MG Gas & Electric

Features 

Panel material: S.S Toughened Glass
Capacity 70L
Function Options: 8
Power: 2300W
Cooling Fan
Control Mode:
Touch Switch
120 minute Mechanical Timing
Led Display Screen
3 Layer Toughened Glass Oven Door
Up: Electrical Heating
Down: Gas Heating
Standard Accessory
Baking Tray: 1Pcs Oven Rack: 1Pcs
Barbecue Fork: 1Pcs
Packing
Gross weight: 35kg
Net weight: 33kg
Package size: (HxWxD)
650X655X660mm

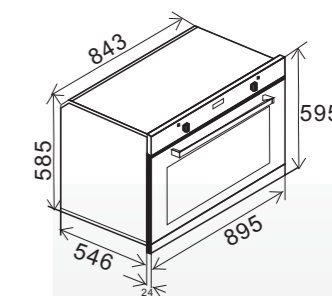

XMS-900S

Features

Panel material: S.S+Toughened Glass

Capacity 125L

Function Options: 9

Power: 2800W

Cooling Fan

Control Mode:

Mechanical Control

With 3 Key Touch Digital Timer

Triple Glazed Removable Door

Cooling Fan

Child Safety Lock

Double Convection Fan

With Rotisserie

Packing

Gross weight: 53.5kg

Net weight: 48.5kg

Package size: (HxWxD)

960X660X650mm



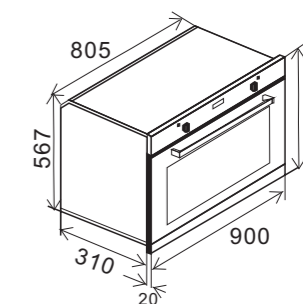

XMS-ZK09

Tempered glass black screen printing

Inner lamp: LED

Steam temperature: 70~100°C

Roasting temperature: 30~220°C

Tank volume: 1.2L

Water Tank Exterior

Maximum steam time: ≥90min

Capacity: 70L

SUS304

Glass fibre

High temperature ink

Galvanized sheet

Accessories are: No hole steam tray *1, With hole steam tub *1

Net weight: 38kg Gross weight: 39kg

Package size: 960 x 500 x 680 mm



XMS-ZK03





XMS-ZK01

High-end atmospheric aluminum handle

White Fully tempered glass S.S

Food grade stainless steel embossed 304 liner

Food grade stainless steel 304 connection oil pan,
steampan

High tempered and moisture resistant furnace lamp

Food grade stainless steel 304 steam generator

Galvanized sheet housing

Food grade PC water tank

Food grade stainless steel 304 grill mesh

Package size: 665 x 620 x 570 mm

Capacity: 40L Power: 2100W

Net weight: 26kg Gross weight: 29kg



XMS-ZK02

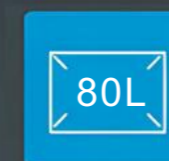
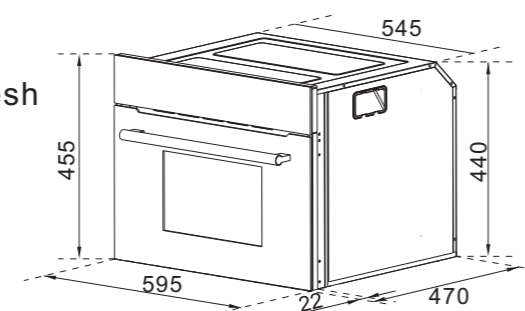

XMS-ZK06

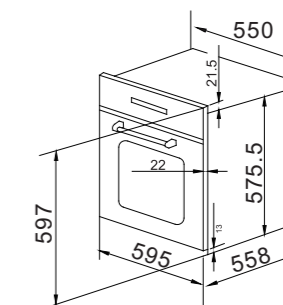

High grade black crystal tempered glass

Main function

capacity 80L steam oven,

4 layers of glass,

4 layers of cooking layering

upper and lower LED lights

Operating temperature 30°C - 250°C

Package size: 655 x 655 x 660 mm

Power: 3100W

Net weight: 35kg Gross weight: 37kg



WBL-03



Easy-Tronic microwave FULL BUILT IN with grill stainless steel
Capacity:25L
Stainless steel Cavity
Microwave Power: 900 w
5 Microwave Power Levels
Speedy Cooking
Kitchen Timer
Defrost By Weight/ Time
Child Ssfety Lock
Gross Weight: 20.5kg
Net Weight: 18.5kg
Package size:
653 x 500 x 466

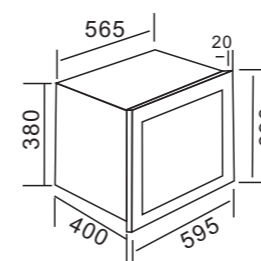

Up 20mm
Down 0 mm

WBL-05



Easi-tronic REAL FULL BUILT-IN microwave tempered glass
White color LED display
Power output 900 Watt, Grill Power:1200W
Push button Door
Capacity 25L
5 power settings
60 minutes digital timer
6 Auto cook menus
Defrost setting, Cooking end signal
Child safety lock
Gross Weight: 15kg
Net Weight: 14kg
Package size:
655 x 440 x 470

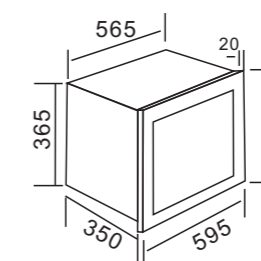

Up 20mm
Down 0 mm

WBL-06



Easy-Tronic microwave FULL BUILT IN with grill stainless steel
Capacity:31L
Output Power: 900 w
5 microwave pwer settings
1200 Watt heating element grill
2 grill power settings
2 combination grill power settings
60 minutes digital timer, 6 Auto menu
24H clock, Push button door
Gross Weight: 23kg
Net Weight: 21kg
Package size:
660 x 466 x 450

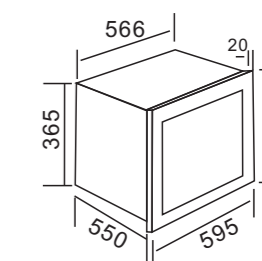

Up 20mm
Down 0 mm

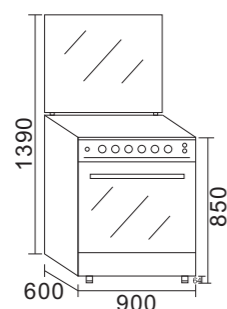

906E2

Hot plate	1. 5*1. 0(kw)
Hob power	3. 4+2. 4+1. 8*2(kw)
Hob top panel	S/S or painted
Hob burner	Brass burner cap Φ120+Φ100+Φ70+Φ70mm
Burner cap	Brass
Pan support	Enamel
Hobignition	Manual or pulse
Knob	Matal or plastic
Oven power	3. 2kw*2
Oven capacity	90L
Oven heating tube	Controlled independently Upper heating tube: 2 pcs Lower heating tube: 1 pcs Rear heating tube: 1 pcs
Oven air fan	Rear
Oven temp. Range	70~250°C by thermostat
Oven timer	0~60 minutes, mechanical
Oven functions	Unfreeze, slow roast, fast roast Side roast, convection roast, etc 11 modes in total
Oven side body	S/S or painted
Oven front panel	S/S or painted
Oven back panel	Zinc plating
Oven door	Double glass
Oven door handle	S/S or alumium
Oven pan	Enameled
Oven rack	Electro-plated
Product size	900x600x850mm
Packing size	950x670x870mm
Gross weight	67kg
Net weight	64kg

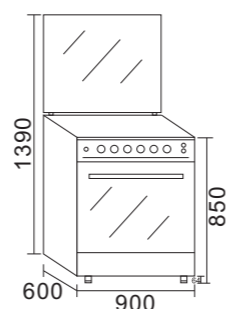

905T

Hob power	3. 4+2. 4+1. 8*2(kw)
Hob top panel	S/S or painted
Hob burner	Brass burner cap Φ120+Φ100+Φ70+Φ70mm
Burner cap	Brass
Pan support	Enamel
Hobignition	Manual or pulse
Knob	Matal or plastic
Oven power	3. 2kw*2
Oven capacity	90L
Oven heating tube	Controlled independently Upper heating tube: 2 pcs Lower heating tube: 1 pcs Rear heating tube: 1 pcs
Oven air fan	Rear
Oven temp. Range	70~250°C by thermostat
Oven timer	0~60 minutes, mechanical
Oven functions	Unfreeze, slow roast, fast roast Side roast, convection roast, etc 11 modes in total
Oven side body	S/S or painted
Oven front panel	S/S or painted
Oven back panel	Zinc plating
Oven door	Double glass
Oven door handle	S/S or alumium
Oven pan	Enameled
Oven rack	Electro-plated
Product size	900x600x850mm
Packing size	950x670x870mm
Gross weight	67kg
Net weight	64kg

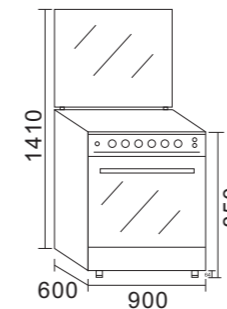

906T

Hob power	3. 4+2. 4+1. 8*2(kw)
Hob top panel	S/S or painted
Hob burner	Brass burner cap Φ120+Φ100+Φ70+Φ50mm
Burner cap	Enamel
Pan support	Enamel
Hobignition	Manual or pulse
Knob	Matal or plastic
Oven power	1.0~3.0kw
Oven capacity	90L
Oven heating tube	Controlled independently Upper heating tube: 2 pcs Lower heating tube: 1 pcs Rear heating tube: 1 pcs
Oven air fan	Rear
Oven temp. Range	70~250°C by thermostat
Oven timer	0~60 minutes, mechanical
Oven functions	Unfreeze, slow roast, fast roast Side roast, convection roast, etc 11 modes in total
Oven side body	S/S or painted
Oven front panel	S/S or painted
Oven back panel	Zinc plating
Oven door	Double glass
Oven door handle	S/S or alumium
Oven pan	Enameled
Oven rack	Electro-plated
Product size	500x500x850mm
Packing size	515x565x870mm
Gross weight	36kg
Net weight	34kg

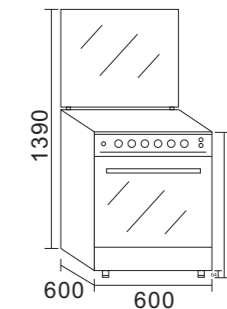

600T

Hob power	3. 4+2. 4+1. 8*2(kw)
Hob top panel	S/S or painted
Hob burner	Brass burner cap Φ120+Φ100+Φ70+Φ70mm
Burner cap	Brass
Pan support	Enamel
Hobignition	Manual or pulse
Knob	Matal or plastic
Oven power	3. 2kw*2
Oven capacity	64L
Oven heating tube	Controlled independently Upper heating tube: 2 pcs Lower heating tube: 1 pcs Rear heating tube: 1 pcs
Oven air fan	Rear
Oven temp. Range	70~250°C by thermostat
Oven timer	0~60 minutes, mechanical
Oven functions	Unfreeze, slow roast, fast roast Side roast, convection roast, etc 11 modes in total
Oven side body	S/S or painted
Oven front panel	S/S or painted
Oven back panel	Zinc plating
Oven door	Double glass
Oven door handle	S/S or alumium
Oven pan	Enameled
Oven rack	Electro-plated
Product size	600x600x850mm
Packing size	620x650x870mm
Gross weight	47kg
Net weight	45kg

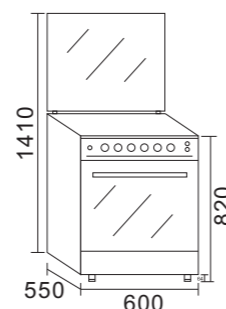
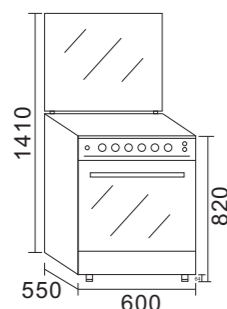

600E2

Hob power	3. 4+2. 4+1. 8*2 (kw)
Hob top panel	S/S or painted
Hob burner	Sabaf burner Φ120+Φ100+Φ70+Φ50mm
Burner cap	Enamel
Pan support	Enamel
Hobignition	Manual or pulse
Knob	Matal or plastic
Oven power	1.0~3.0kw
Oven capacity	64L
Oven heating tube	Controlled independently Upper heating tube: 2 pcs Lower heating tube: 1 pcs Rear heating tube: 1 pcs
Oven air fan	Rear
Oven temp. Range	70~250°C by thermostat
Oven timer	0~60 minutes, mechanical
Oven functions	Unfreeze, slow roast, fast roast Side roast, convection roast, etc 11 modes in total
Oven side body	S/S or painted
Oven front panel	S/S or painted
Oven back panel	Zinc plating
Oven door	Double glass
Oven door handle	S/S or alumium
Oven pan	Enameled
Oven rack	Electro-plated
Product size	600x570x840mm
Packing size	605x660x890mm
Gross weight	35kg
Net weight	32kg

600S

Hob power	3. 4+2. 4+1. 8*2 (kw)
Hob top panel	S/S or painted
Hob burner	Brass burner cap Φ120+Φ100+Φ70+Φ50mm
Burner cap	Brass
Pan support	Enamel
Hobignition	Manual or pulse
Knob	Matal or plastic
Oven power	1.0~3.0kw
Oven capacity	64L
Oven heating tube	Controlled independently Upper heating tube: 2 pcs Lower heating tube: 1 pcs Rear heating tube: 1 pcs
Oven air fan	Rear
Oven temp. Range	70~250°C by thermostat
Oven timer	0~60 minutes, mechanical
Oven functions	Unfreeze, slow roast, fast roast Side roast, convection roast, etc 11 modes in total
Oven side body	S/S or painted
Oven front panel	S/S or painted
Oven back panel	Zinc plating
Oven door	Double glass
Oven door handle	S/S or alumium
Oven pan	Enameled
Oven rack	Electro-plated
Product size	600x570x840mm
Packing size	605x660x890mm
Gross weight	35kg
Net weight	32kg

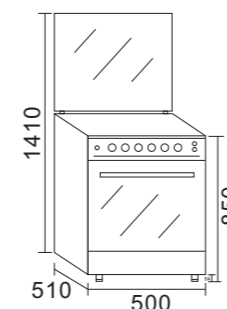

500S

Hob power	3. 4+2. 4+1. 8*2 (kw)
Hob top panel	S/S or painted
Hob burner	Brass burner cap Φ120+Φ100+Φ70+Φ50mm
Burner cap	Enamel
Pan support	Enamel
Hobignition	Manual or pulse
Knob	Matal or plastic
Oven power	1.0~3.0kw
Oven capacity	51L
Oven heating tube	Controlled independently Upper heating tube: 2 pcs Lower heating tube: 1 pcs Rear heating tube: 1 pcs
Oven air fan	Rear
Oven temp. Range	70~250°C by thermostat
Oven timer	0~60 minutes, mechanical
Oven functions	Unfreeze, slow roast, fast roast Side roast, convection roast, etc 11 modes in total
Oven side body	S/S or painted
Oven front panel	S/S or painted
Oven back panel	Zinc plating
Oven door	Double glass
Oven door handle	S/S or alumium
Oven pan	Enameled
Oven rack	Electro-plated
Product size	500x500x850mm
Packing size	515x565x870mm
Gross weight	36kg
Net weight	34kg

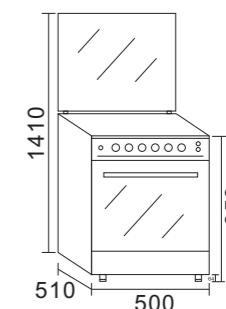

500E4

Hob power	3. 4+2. 4+1. 8*2 (kw)
Hob top panel	S/S or painted
Hob burner	Brass burner cap Φ120+Φ100+Φ70+Φ50mm
Burner cap	Enamel
Pan support	Enamel
Hobignition	Manual or pulse
Knob	Matal or plastic
Oven power	1.0~3.0kw
Oven capacity	51L
Oven heating tube	Controlled independently Upper heating tube: 2 pcs Lower heating tube: 1 pcs Rear heating tube: 1 pcs
Oven air fan	Rear
Oven temp. Range	70~250°C by thermostat
Oven timer	0~60 minutes, mechanical
Oven functions	Unfreeze, slow roast, fast roast Side roast, convection roast, etc 11 modes in total
Oven side body	S/S or painted
Oven front panel	S/S or painted
Oven back panel	Zinc plating
Oven door	Double glass
Oven door handle	S/S or alumium
Oven pan	Enameled
Oven rack	Electro-plated
Product size	500x500x850mm
Packing size	515x565x870mm
Gross weight	36kg
Net weight	34kg



XW-Q01

- *Black tempered glass with embedded handle
- *LED touch button
- *SUS304 stainless steel interior door
- *Standard automatic distributor water softener and LED white light
- *High temperature disinfection waste heat drying
- *Packing: 680x710x605
- Gross Weight: 34kg**
- Net Weight: 29.5kg**

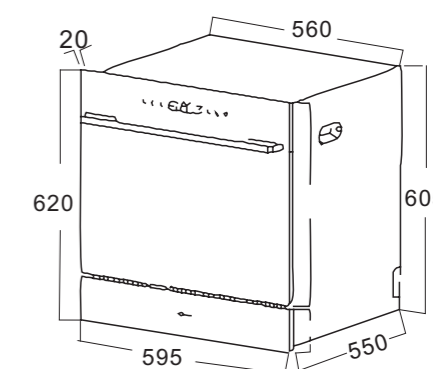

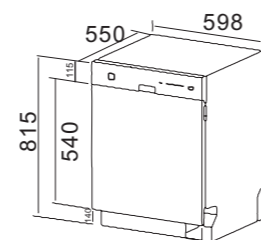

XW-Q03

FEATURES

- + 12/14 place settings
- + Optional three-layer cutlery drawer
- + Half load
- + 3/6/9 hours delay start

SPECIFICATIONS

- + A++ energy efficiency class
- + 6 wash programmes: Intensive/Normal/Eco/Glass/90 min/Rapid
- + Packing (HxWxD, mm): 890x645x645
- Gross Weight: 42kg
- Net Weight: 35kg

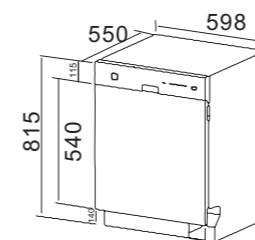

XW-Q04

FEATURES

- + 12/14 place settings
- + Optional three-layer cutlery drawer
- + Half load
- + 3/6/9 hours delay start

SPECIFICATIONS

- + A++ energy efficiency class
- + 6 wash programmes: Intensive/Normal/Eco/Glass/90 min/Rapid
- + Packing (HxWxD, mm): 890x645x645
- Gross Weight: 42kg
- Net Weight: 35kg

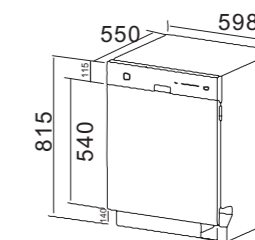

XW-Q05

FEATURES

- + 12/14 place settings
- + Optional three-layer cutlery drawer
- + Half load
- + 3/6/9 hours delay start

SPECIFICATIONS

- + A++ energy efficiency class
- + 6 wash programmes: Intensive/Normal/Eco/Glass/90 min/Rapid
- + Packing (HxWxD, mm): 890x645x645
- Gross Weight: 42kg
- Net Weight: 35kg



36 bottle wine refrigerator

JG-05

Capacity:83L;
 Wine storage: 36 bottles;
 Adjustable temperature:Upper:5-12°C(41-54F),Lower:12-20°C(54-68°F);
 Adjustable handcrafted natural beech wooden shelves without chemical aromas influence to wines flavours and looks attractive;
 Built-in installation design;
 Dual temperature zone;
 Touch pad digital control with LED readout,
 Celsius & Fahrenheit display;
 No frost with interior fan circulating;
 LED interior lighting enhances visibility;
 Tempered glass door with stainless steel trim;

Product(WxDxH):590x565x595mm
 Packaging(WxDxH):656X620x645mm



Digital Temp Display



Seamless S.S door with S.S handle



Wooden Shelves

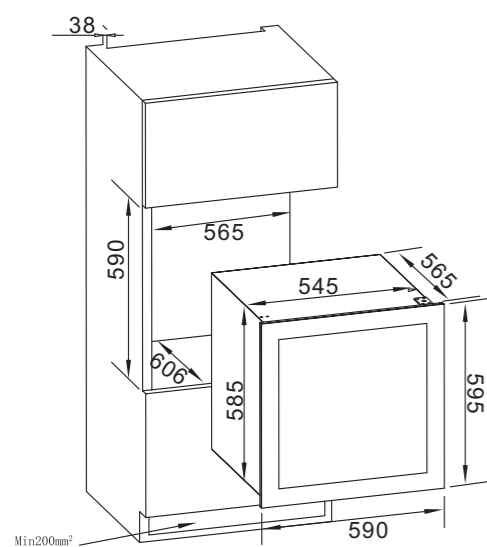

Installation drawing





76 bottles wine refrigerator

JG-06

- Capacity: 236L
- Wine storage: 76 bottles
- Adjustable temperature: 4-18°C (40-65°F)
- Adjustable handcrafted natural beech wooden shelves without chemical aromas influence to wines flavours and looks attractive
- Built-in design
- Single temperature zone
- Touch pad digital control with white LED readout
- Celsius & Fahrenheit display
- No frost with interior fan circulating
- LED interior lighting enhances visibility
- Unique door hinge
- Tempered glass door with integrated handle

Product(WxDxH):593x505x1786mm
Packaging(WxDxH):655x570x1995mm



Digital Temp Display



German door hinge



Wooden Shelves

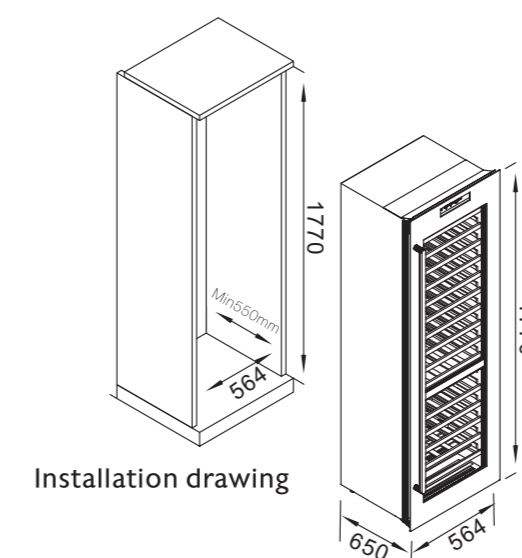

XiMengsi pivotal advantages.

- * Suits desires of clients in household and commercial purposes
- * Elegant, human-based design and perfect functionality
- * Highly well-trained and experienced technical team ensures continually developing and producing a wide range of new and patented products
- * In all of the products for you will find consistent exclusive look and high quality.
- * Specialist and solution provider in wine and cigar storage.
- * Always willing to put the customers first and do utmost to help them build up reputation and create value.



TWO DOOR SERIES

184 bottles wine refrigerator

JG-08

Capacity: 500

Wine storage: 184 bottles

Adjustable temperature: 5 ° C-20 ° C left / 5 ° C-20 ° C right

Shelf: Log colored wood trim

Gate Body: Whole Glass Gate

Display: door display, touch digital control,

Fahrenheit and Celsius display

Cooling method: air-cooled without frost

Lighting LED interior lighting

Warm zone The left and right two independent warm zone

Hole size: width 900 mm* height 1770 mm* depth 620 mm

Box size: 885 mm* height 1765 mm* depth 600 mm

Package size: 1005 mm* Height 1915 mm* Depth 730 mm

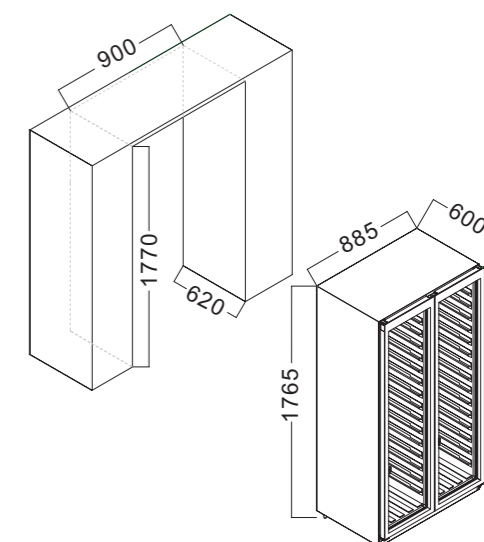



JG-01



JG-02



JG-03



Features:

Toughened glass

Digital temperature control with LED display

Fahrenheit and Celsius degree temperature indicator interior

Light with ON/OFF switch

Wooden shelves for option

R134a or R600a refrigerant

Model		JG-01	JG-02	JG-03
Current safety approval		CE, GS, ETL, RoHS	CE, GS, ETL, RoHS	CE, GS, ETL, RoHS
Temperature range		5°C-18°C	4°C-18°C	5°C-18°C
Quantity per Container	20' container	60	112	192
	40' container	124	240	400
	40'HC container	184	276	498
Dimension	Product (WxDxH) mm	480x470x130	480x490x835	430x480x510
	Packing (WxDxH) mm	510x520x1335	510x520x870	480x535x530
Weight	Net weight (kg)	42	28	14
	Gross weight (kg)	45	31	16.5

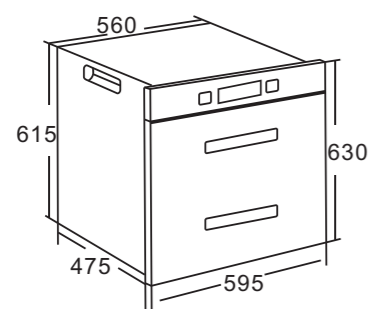

110-K1

Technical Parameters

Rated power supply: 220v~50hz
 Rated power: 515w
 Rated volume: 100L
 Control method: Touch switch
 Door panel main material:
 Tempered glass
 Disinfection method:
 Drying + high temperature
 Gross Weight: 17kg
 Net Weight: 15kg
 Packing size:
 655 x 580 x 718

Features

(Can be customized: UV disinfection)
 The upper layer is low temperature, the lower layer is high temperature antivirus, the black tempered glass panel is simple and fashionable, the stainless steel plate dish rack, humanized design, larger storage space, touch smart switch, LED + digital display, ABS hidden handle, elegant and stylish, precise door control switch device, open the door automatic power-off function, hidden mute rails, prevent the tableware from secondary pollution and durable

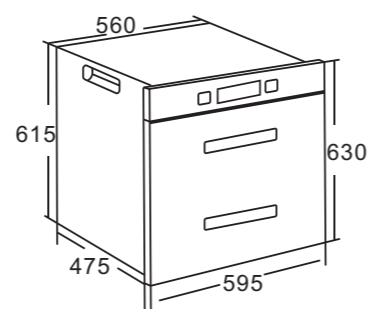

110-K3

Technical Parameters

Rated power supply: 220v~50hz
 Rated power: 515w
 Rated volume: 120L
 Control method: Touch switch
 Door panel main material:
 Tempered glass
 Disinfection method:
 Drying + high temperature
 Gross Weight: 17kg
 Net Weight: 15kg
 Packing size:
 655 x 580 x 718

Features

(Can be customized: UV disinfection)
 The upper layer is low temperature, the lower layer is high temperature antivirus, the black tempered glass panel is simple and fashionable, the stainless steel plate dish rack, humanized design, larger storage space, touch smart switch, LED + digital display, ABS hidden handle, elegant and stylish, precise door control switch device, open the door automatic power-off function, hidden mute rails, prevent the tableware from secondary pollution and durable



JC-05

Integrated gas cooker

Features:
 Integrated gas cooker

Rated voltage
 220V
 Rated power
 650W
 Maximum static pressure Pa
 >500Pa
 Air volume:
 18m³/min
 Rated heat load: T
 left 5.0kW/right 5.0kW, Y: Left 4.5kW/Right 4.5kW

Gross Weight: 102kg
 Net Weight: 93kg
 Packing size:
 980 x 712 x 1200

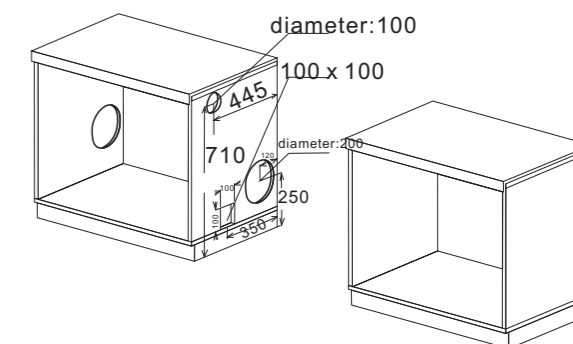
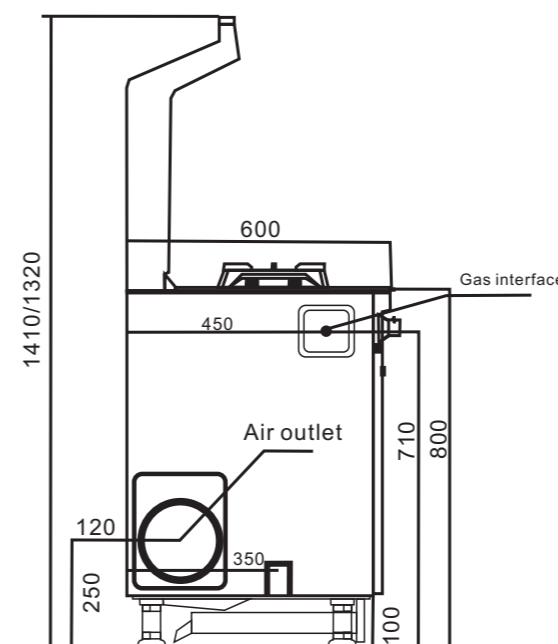



BX-04



Capacity: 265L (200L/Fridge,65L/Freezer);
Adjustable temperature: Fridge room 1-10°C(34-50°F)
Freezer room 0~-30°C (32~-22°F)

No. of glass shelves: 3;
Crystal Vegetable Crisper: 2 half-width;
No. of freezer drawers: 3;
Built-in design;
Electronic control with LED/LCD display;
No frost with interior fan circulating;
LED interior lighting enhances visibility;
Reversible door;
Low power consumption;
Super storage conditions;

N.W/ G.W: 52/57kg

Packing(WxDxH): 580x580x1830mm;

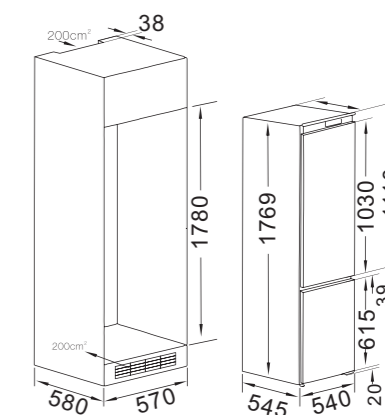



BX-12

L Capacity: 228L
 Freezing: 228L
 N.W/ G.W: 52/60kg
 packing: 580x590x1840

R Capacity: 316L
 Cold storage: 316L
 N.W/ G.W: 58/62kg
 packing: 580x590x1840

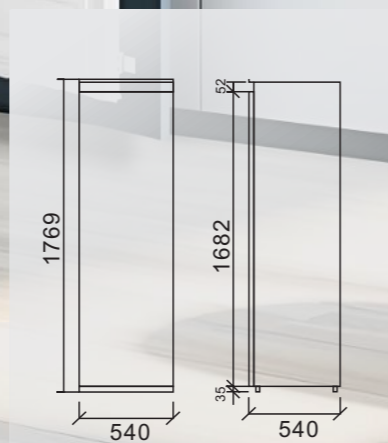

BX-08



Capacity: 117L
 Cold storage: 100L
 Freezing: 17L
 N.W/ G.W: 30/33kg
 size: 595x540x825
 packing: 620x565x850

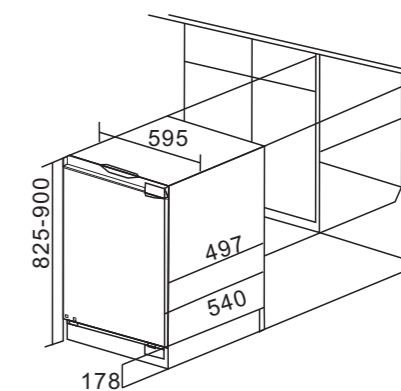

**BX-09**

Capacity: 62L
 N.W/ G.W: 13/15kg
 size: 430x485x640
 packing: 460x540x660

BX-07

Capacity: 40L
 N.W/ G.W: 14/16.5kg
 size: 430x410x510
 packing: 460x440x530

BX-03

Capacity: 213L (113L+44L+56L)
 N.W/ G.W: 47/49kg
 size: 544x595x1725
 packing: 610x650x1780

BX-06

Capacity: 325L (169L+132L+24L)
 N.W/ G.W: 71/74kg
 size: 635x690x1855
 packing: 701x722x1933

BX-10

Capacity: 606L
 N.W/ G.W: 103/113kg
 size: 911x700x1780
 packing: 968x750x1845

BX-11

Capacity: 690L
 N.W/ G.W: 75/83kg
 size: 910x630x1836
 packing: 965x650x1910

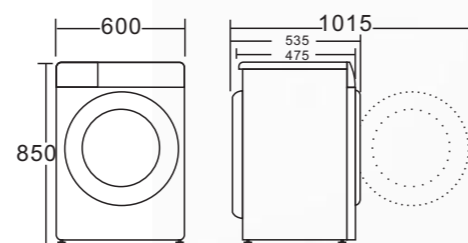

XMS-XYJ-01

Washing capacity:10.5kg

DD Dirct drive frequency conveqson

Steam sterilization washing

Gross weight :73kg

Net weight :71kg

Packing size : 660 x 660 x 880 mm

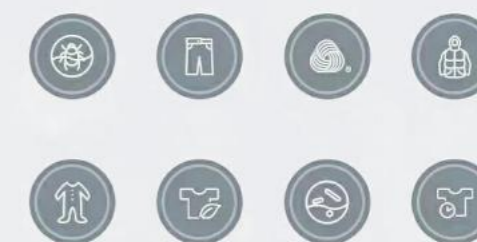

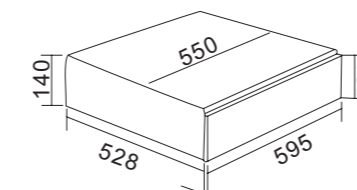
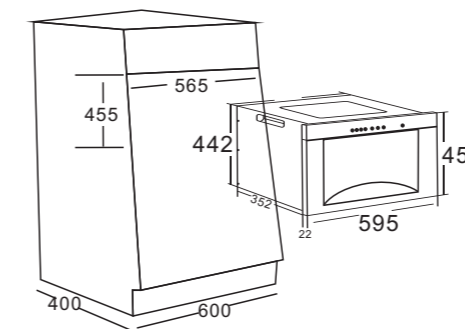

XMS-235-2

Built in coffee machine

Switch:touch screen

Voltage:220-240V

Coffee volume adjustable

Removable water tank 1.8L

Automatic cleaning system

Pump max pressure(bar):19bar

Standby function

Black

N.W/ G.W: 25/29kg

Packing size:600x660x560mm

ND-01

Easy tronic control panel with

Red Led, 2.Handle, 3 Anti-slip Mat

Suitable for Fitting 45cm Height Compact oven

Temperature Range From 30'C to 75'C, 5'C per step

Adjustable timer with automatic switch off

No slip drawer liner

Black

N.W/ G.W: 7/8kg

Packing size:670x645x210mm



XMS-235-1

Coffee machines
 Switch: Touch screen
 Voltage: 220-240V
 Frequency: 50Hz/60Hz
 Water-tank Capacity: 2000ml
 Bean-tank Capacity: 250g
 Max system pressure: 15bar ULKA Pump from Italy
 Power: 1250W-1500W
 Product size(WxHxD): 595x455x550mm
 Packing size: 600x660x560mm
 Bulid-in Depth: 53cm
 N.W/ G.W: 21/25kg

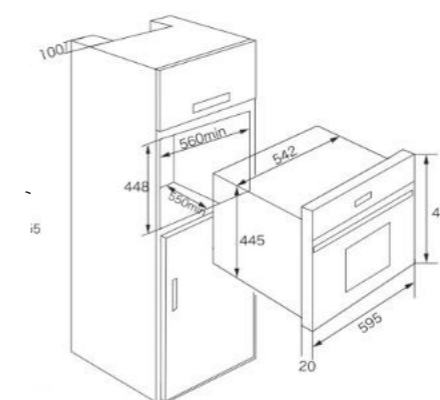

ND-02

Easy tronic control panel with
 Red Led, 2.Handle, 3 Anti-slip Mat
 Suitable for Fitting 45cm Height Compact oven
 Temperature Rnage From 30'C to 75'C, 5'C per step
 Adjustable timer with automatic switch off
 No slip drawer liner
 S.S
 N.W/ G.W: 7/8kg
 Packing size: 670x645x210mm

